

**321 454 300 143**

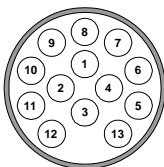

**VW T5 GP (RHD) van, bus, 10/2009 →**  
**VW T5 GP (RHD) pickup, 10/2009 →**

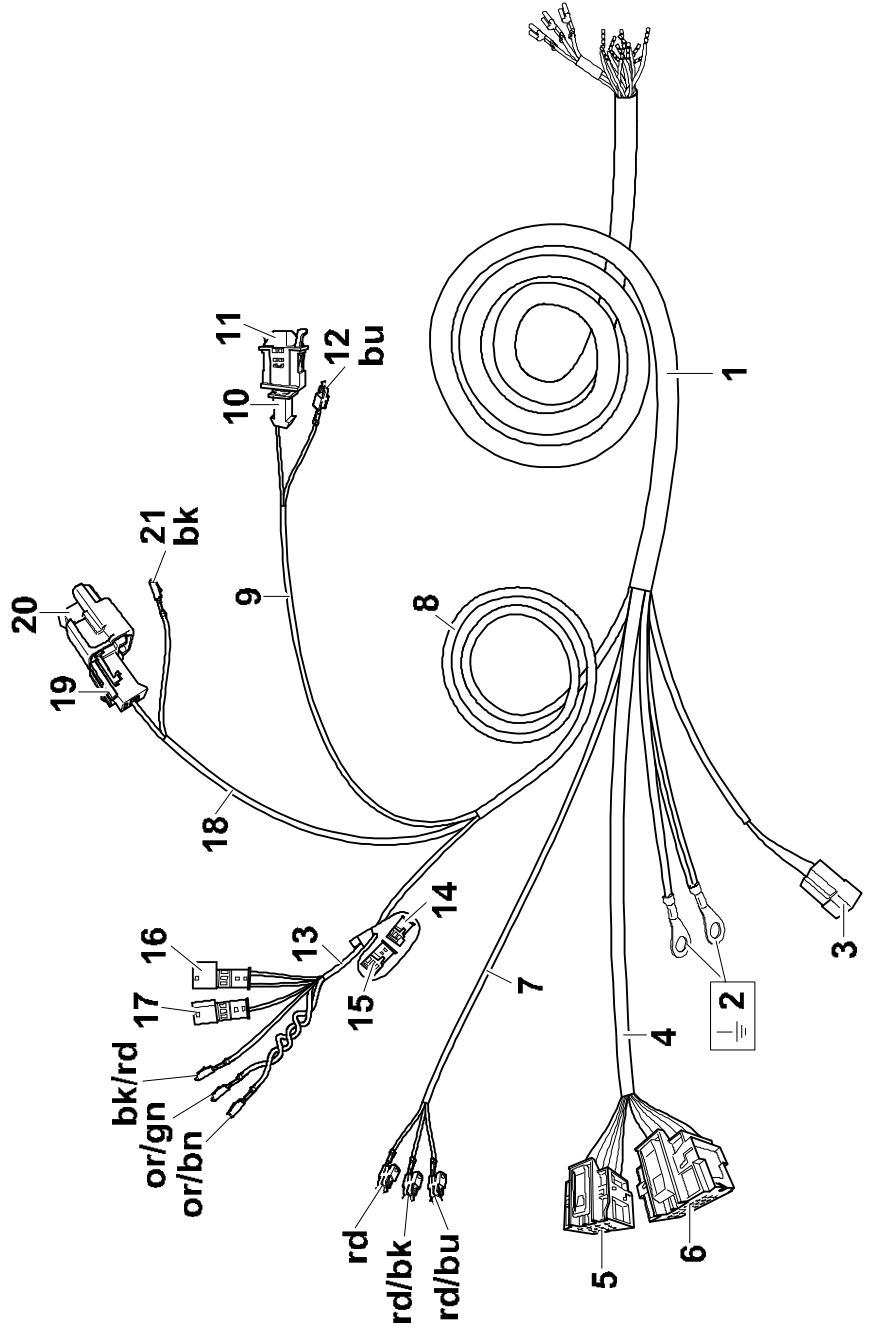

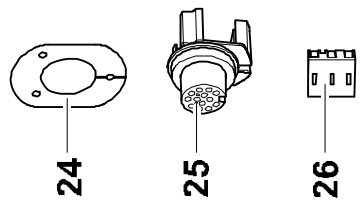
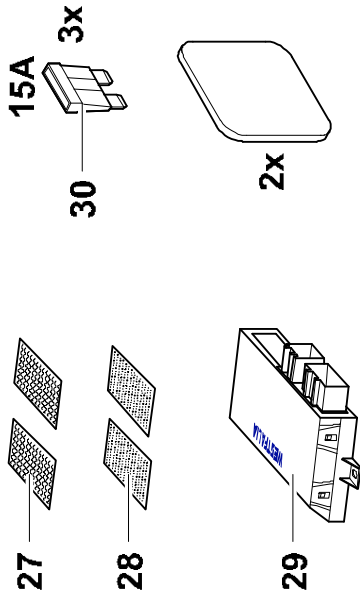
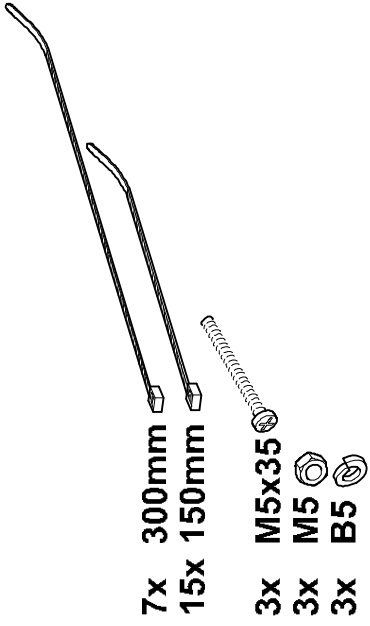
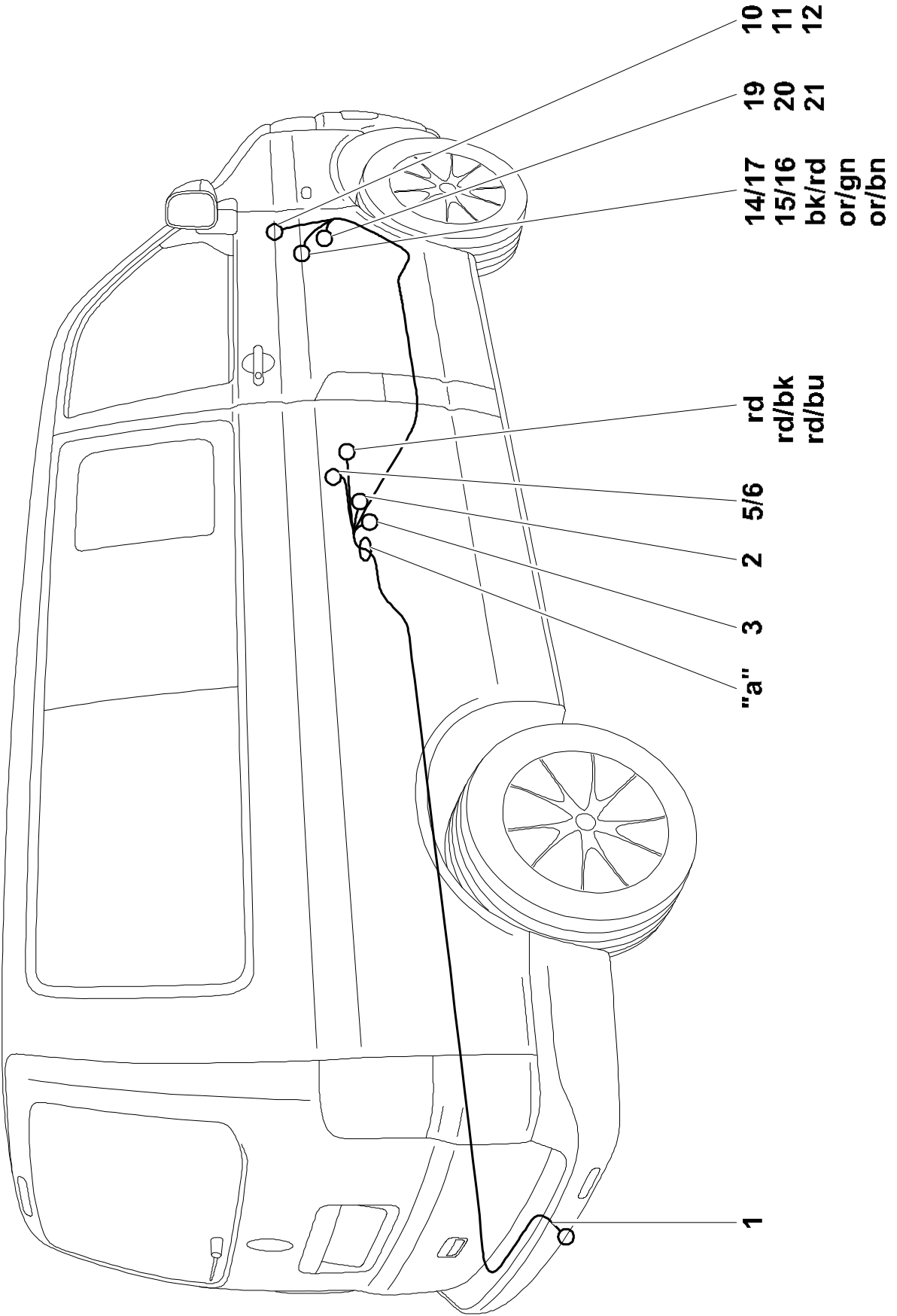

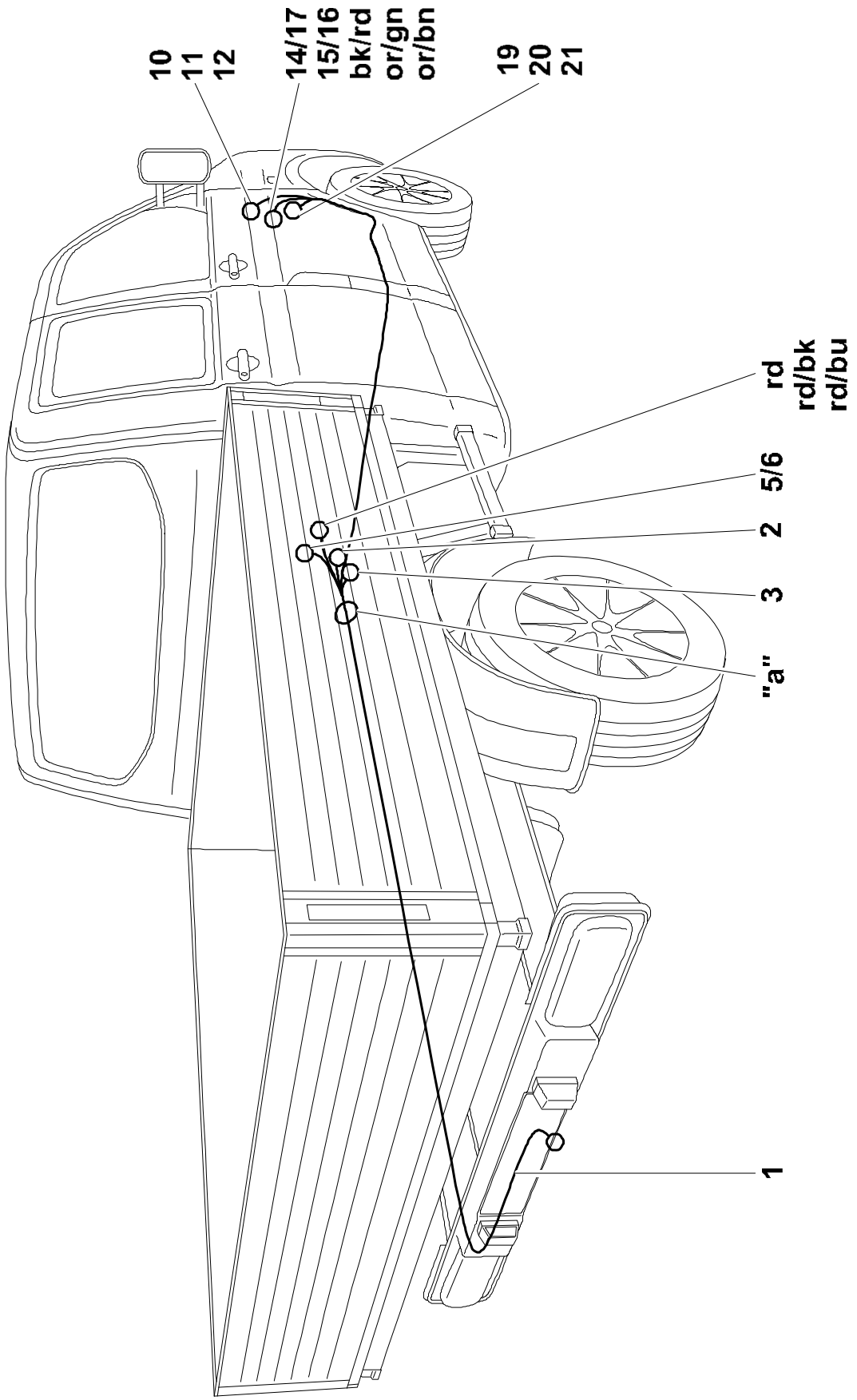

|           |                                     |            |                                    |            |                          |
|-----------|-------------------------------------|------------|------------------------------------|------------|--------------------------|
| <b>D</b>  | Steckdosenbelegung                  | <b>CZ</b>  | Obsazení zásuvky                   | <b>DK</b>  | Koblingskema             |
| <b>E</b>  | Esquema de tomas de enchufe         | <b>F</b>   | Affectation des prises électriques | <b>FIN</b> | Pistorasian navat        |
| <b>GB</b> | Pin assignment                      | <b>GR</b>  | Αντιστοιχία πριζας                 | <b>HU</b>  | Csatlakozódugó leosztása |
| <b>I</b>  | Schema dei collegamenti della presa | <b>N</b>   | Kontaktksjema                      | <b>NL</b>  | Contactdoosbezetting     |
| <b>PL</b> | Rozkład pinów                       | <b>RUS</b> | Разводка розеток                   | <b>S</b>   | Stickdosschema           |

|  |  | <b>S</b>    | <b>RUS</b>          | <b>PL</b>         | <b>NL</b>    | <b>N</b>     | <b>I</b>        | <b>HU</b>      | <b>GR</b>      | <b>GB</b>    | <b>FIN</b>        | <b>F</b>      | <b>E</b>       | <b>DK</b> | <b>CZ</b>     | <b>D</b>      |            |             |  |
|--|--|-------------|---------------------|-------------------|--------------|--------------|-----------------|----------------|----------------|--------------|-------------------|---------------|----------------|-----------|---------------|---------------|------------|-------------|--|
| <p>1 = gy<br/>2 = gy/bu<br/>3 = bu</p> |  | svart/ vit  | черный/ белый       | czarno/ biały     | zwart/ wit   | svart/ hvit  | nero/ bianco    | fekete/fe hér  | μαύρο/ λευκό   | black/ white | musta/va lkoinen  | noir/ blanc   | negro/ blanco  | sort/hvid | černobilá     | schwarz/ weiß |            |             |  |
|  |  | grá /blá    | серый /голубой      | szaro /niebieski  | grijs /blauw | grá /blá     | grigio /blu     | szürke /kék    | γκρι /μπλε     | grey /blue   | harmaa /sininen   | gris / bleu   | gris /azul     | grá /blá  | šedo /modrý   | grau/ blau    |            | 1<br>(L)    |  |
|  |  | Brun        | коричне вый         | brązowo           | bruin        | brun         | marrone         | barna          | καφέ           | brown        | ruskea            | marron        | marrón         | brun      | hnědá         | braun         |            | 2<br>(54g)  |  |
|  |  | svart/ grön | черный/ зеленый     | czarno/ zielony   | zwart/ groen | svart/ grønn | nero/ verde     | fekete/zöld    | μαύρο/ πράσινο | black/ green | musta/vi hreä     | noir/vert     | negro/ verde   | sort/grön | černo zelená  | schwarz/ grün |            | 3<br>(31)   |  |
|  |  | grá/ ród    | серый/красный       | szaro/ czerwony   | grijs/ rood  | grá/rød      | grigio/ rosso   | szürke/pi ros  | γκρι/ κόκκινο  | gray/ red    | harmaa/ punainen  | gris/ rouge   | gris/rojo      | grá/rød   | šedo červená  | grau/rot      |            | 4<br>(R)    |  |
|  |  | svart/ ród  | черный/красный      | czarno/ czerwony  | zwart/ rood  | svart/ rød   | nero/ rosso     | fekete/piros   | μαύρο/ κόκκινο | black/ red   | musta/pu nainen   | noir/ rouge   | negro/ rojo    | sort/rød  | černo červená | schwarz/ rot  |            | 5<br>(58R)  |  |
|  |  | grá/ svart  | серый/ч ерный       | szaro/ czarny     | grijs/ zwart | grá/ svart   | grigio/ nero    | szürke/fe kete | γκρι/ μαύρο    | gray/ black  | harmaa/ musta     | gris/ noir    | gris/ negro    | grá/sort  | šedočern á    | grau/ schwarz |            | 6<br>(54)   |  |
|  |  | Svart/ blá  | Черный/ голубой     | Czarno/ niebieski | Zwart/ blauw | Svart/ blå   | Nero/ blu       | Fekete/ kék    | Μαύρο/ μπλε    | Black/ blue  | Musta/ sininen    | Noir/ bleu    | Negro/ azul    | Sort/ blå | Černo/ modrý  | schwarz/ blau |            | 7<br>(58L)  |  |
|  |  | ród         | красный             | czerwon y         | rood         | rød          | rosso           | piros          | κόκκινο        | red          | punaine n         | rouge         | rojo           | rød       | červená       | rot           |            | 8           |  |
|  |  | gul         | желтый              | żółty             | geel         | gul          | giallo          | sárga          | σάργα          | yellow       | keltainen         | jaune         | amarillo       | gul       | žlutá         | gelb          |            | 9<br>(+30)  |  |
|  |  | brun/ vit   | коричне вый/бел вый | brązowo/ biały    | bruin/ wit   | brun/hvit    | marrone/ bianco | barna/fe hér   | καφέ/ λευκό    | brown/ white | ruskea/v alkoinen | marron/ blanc | marrón/ blanco | brun/hvid | hnědobíl á    | braun/ weiß   |            | 10<br>(+15) |  |
|  |  | --          | --                  | --                | --           | --           | --              | --             | --             | --           | --                | --            | --             | --        | --            | --            |            | 11<br>(31)  |  |
|  |  | brun        | коричне вый         | brązowo           | bruin        | brun         | marrone         | barna          | καφέ           | brown        | ruskea            | marron        | marrón         | brun      | hnědá         | braun         |            | 12          |  |
|  |  |             |                     |                   |              |              |                 |                |                |              |                   |               |                |           |               |               | 13<br>(31) |             |  |

|            | <b>bk</b> | <b>wh</b> | <b>bn</b>  | <b>gn</b> | <b>gy</b> | <b>rd</b> | <b>ye</b> | <b>bu</b> | <b>or</b>    | <b>pu</b> |
|------------|-----------|-----------|------------|-----------|-----------|-----------|-----------|-----------|--------------|-----------|
| <b>D</b>   | schwarz   | weiß      | braun      | grün      | grau      | rot       | gelb      | blau      | orange       | violett   |
| <b>CZ</b>  | černo     | bílá      | hnědá      | zelená    | šedo      | červená   | žlutá     | modrý     | oranžový     | fialový   |
| <b>DK</b>  | sort      | hvid      | brun       | grøn      | grå       | rød       | gul       | blå       | orange       | violet    |
| <b>E</b>   | negro     | blanco    | marrón     | verde     | gris      | rojo      | amarillo  | azul      | anaranja-do  | violeta   |
| <b>F</b>   | noir      | blanc     | marron     | vert      | gris      | rouge     | jaune     | bleu      | orange       | violet    |
| <b>FIN</b> | musta     | valkoinen | ruskea     | vihreä    | harmaa    | punainen  | keltainen | sininen   | oranssi      | violetti  |
| <b>GB</b>  | black     | white     | brown      | green     | grey      | red       | yellow    | blue      | orange       | purple    |
| <b>GR</b>  | μαύρο     | λευκό     | καφέ       | πράσινο   | γκρι      | κόκκινο   | κίτρινο   | μπλε      | πορτοκαλί    | Μωβ       |
| <b>HU</b>  | fekete    | fehér     | barna      | zöld      | szürke    | piros     | sárga     | kék       | narancssárga | ibolyakék |
| <b>I</b>   | nero      | bianco    | marrone    | verde     | grigio    | rosso     | giallo    | blu       | arancione    | viola     |
| <b>N</b>   | svart     | hvit      | brun       | grønn     | grå       | rød       | gul       | blå       | oransje      | fiolett   |
| <b>NL</b>  | zwart     | wit       | bruin      | groen     | grijs     | rood      | geel      | blauw     | oranje       | violet    |
| <b>PL</b>  | czarno    | biały     | brązowo    | zielony   | szaro     | czerwony  | żółty     | niebieski | pomarańczowe | fioletowe |
| <b>RUS</b> | черный    | белый     | коричневый | зеленый   | серый     | красный   | желтый    | голубой   | оранжевый    | пурпурный |
| <b>S</b>   | svart     | vit       | brun       | grön      | grå       | röd       | gul       | blå       | orange       | violett   |

Observe national guidelines on the approval of accessories.

Any alteration or modification of the electrical system is prohibited and voids the operating licence.

Read the installation manual before beginning to work.

Only qualified companies may install the electrical system for the trailer hitch. Improper assembly may result in a serious accident hazard!

Attention – before starting to work, read out the errors stored in the memory. If required, use a power supply to prevent electronically saved data from being erased. Disconnect the battery to prevent damage to the vehicle electronics.

Verify that no cables are squeezed or damaged. Properly install all seals.

When towing a trailer, the rear fog light of the pulling vehicle is switched off.

An electrical socket adapter may only be used when towing a trailer.

- A failure of the trailer turn signal lamps is indicated by an increased flashing rate of the pilot lamp in the cockpit.

**Check the trailer functions with a trailer or a testing instrument with load resistors.**

The German text of this instruction is binding.

Subject to change.

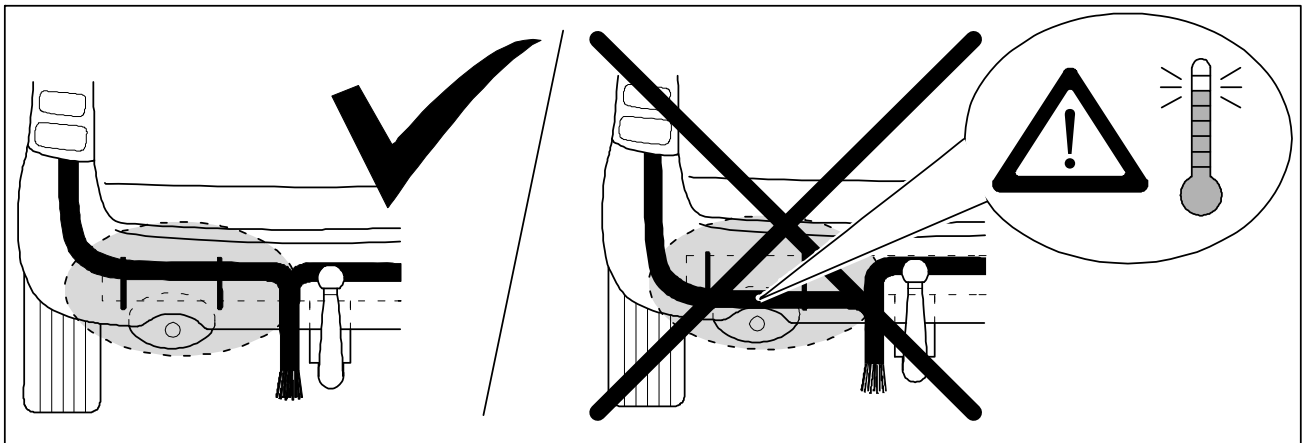
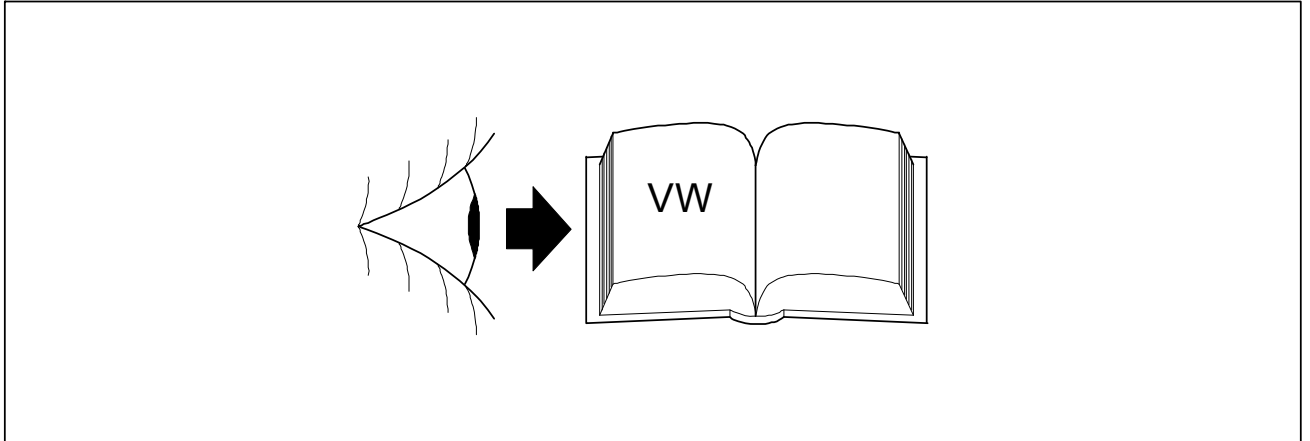

1

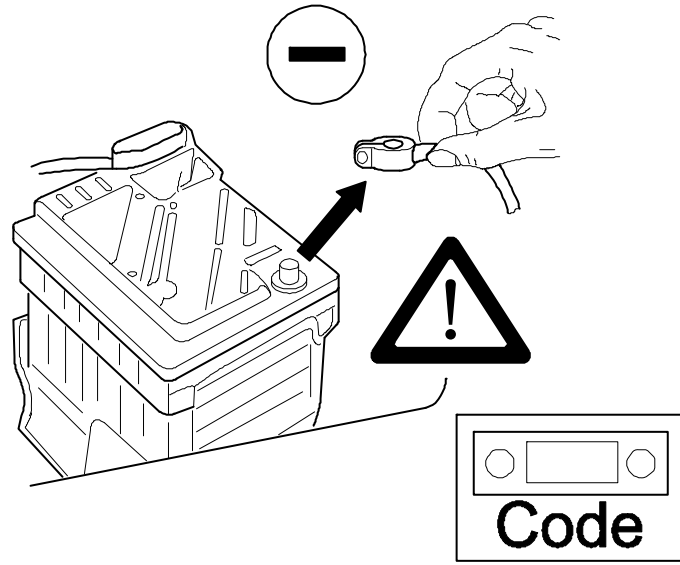

2

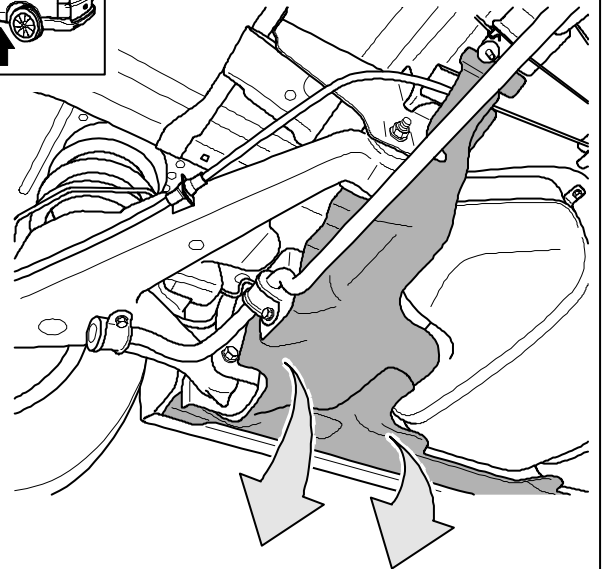
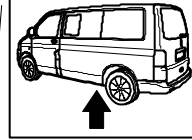
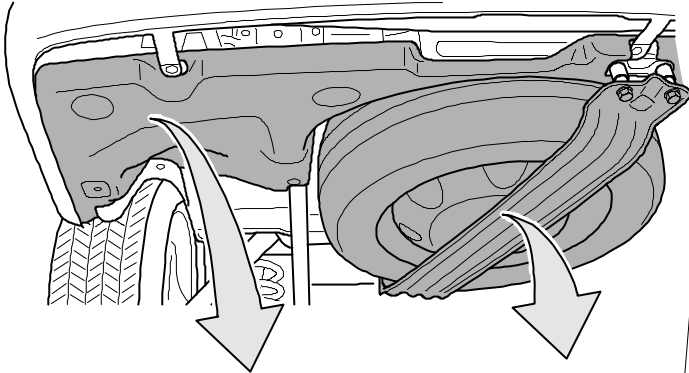
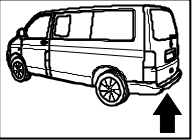

3

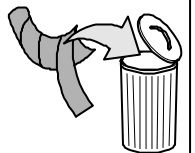
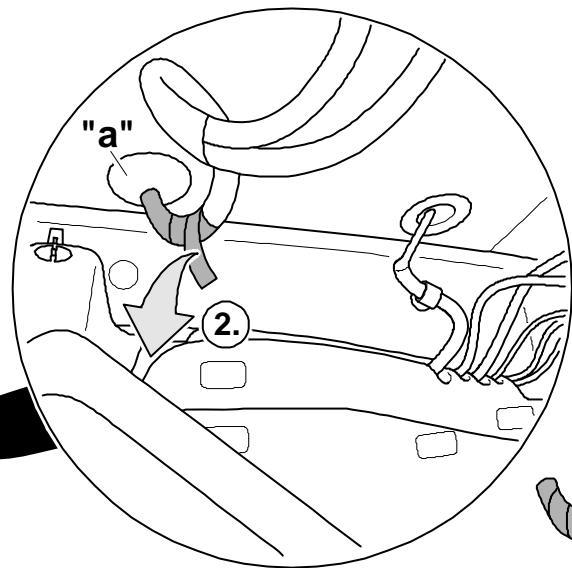
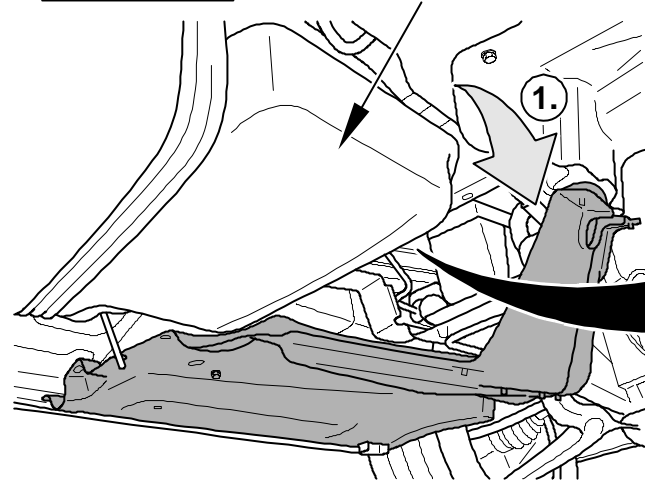
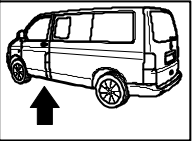



4

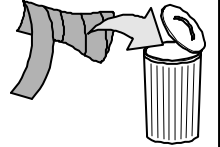
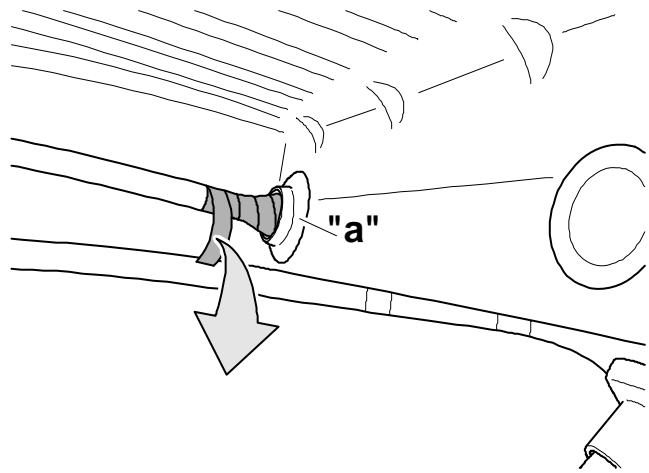
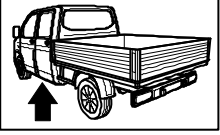

5

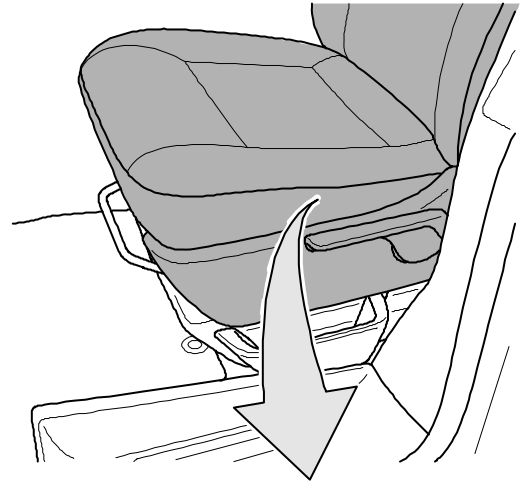
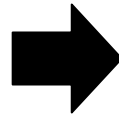
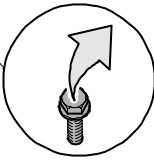
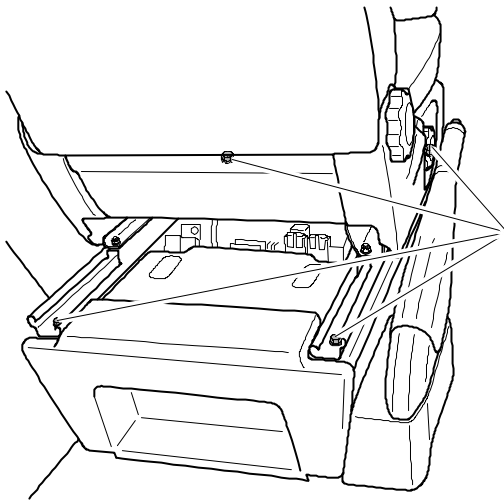
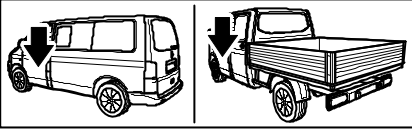

6

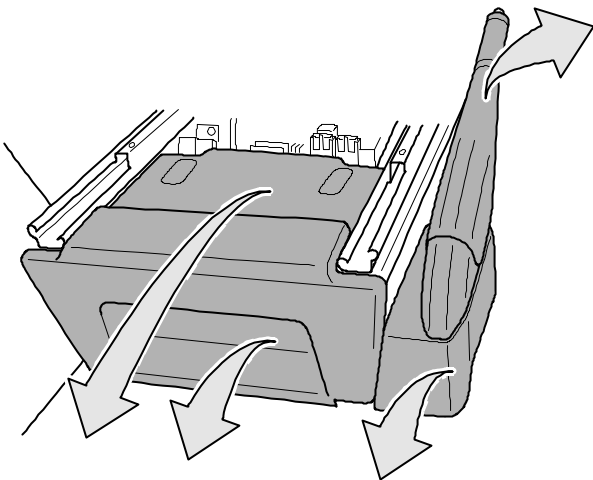
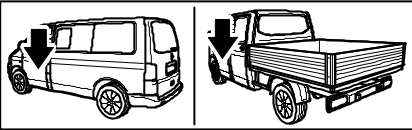

"b"

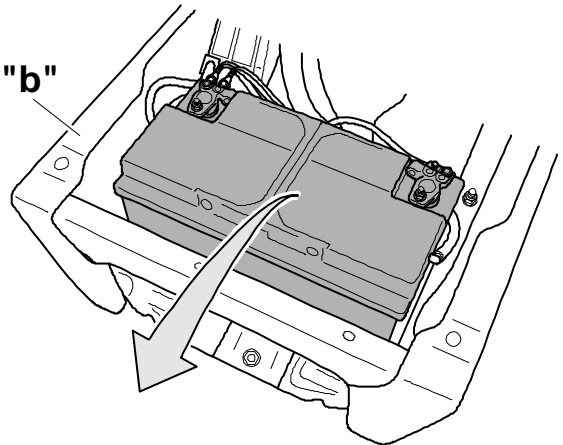

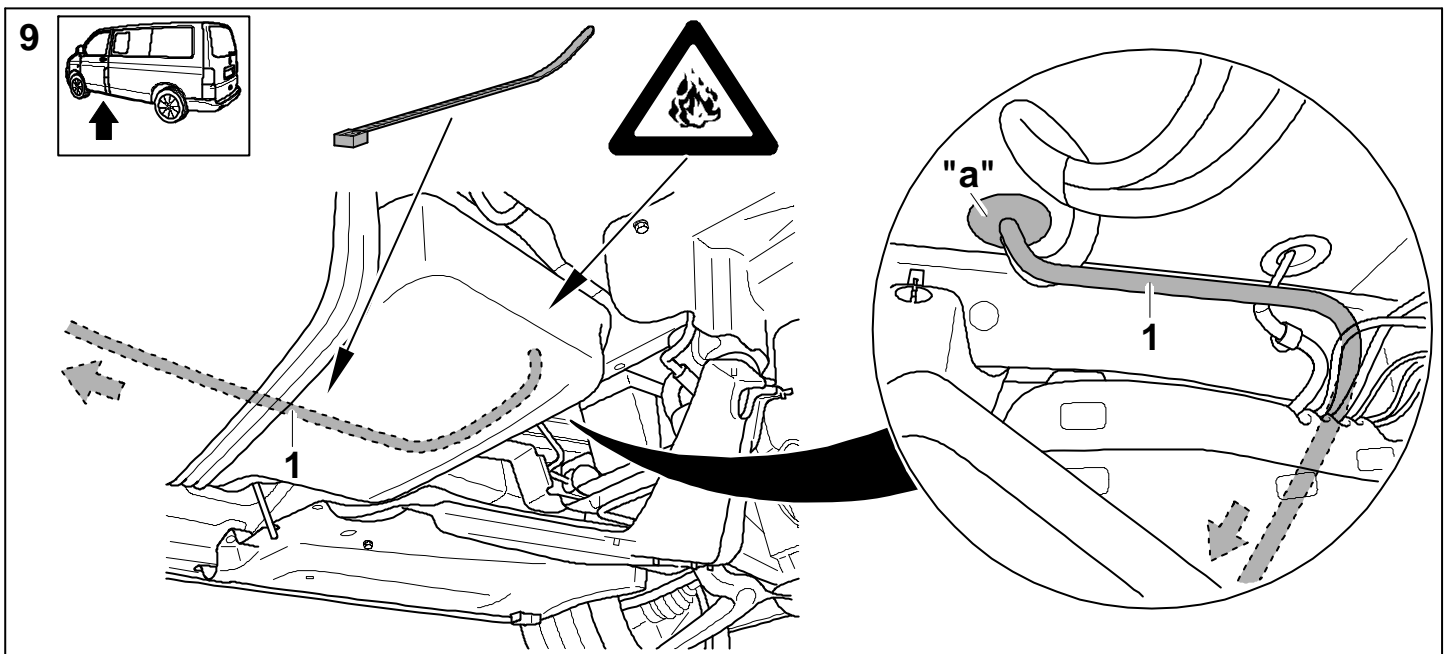
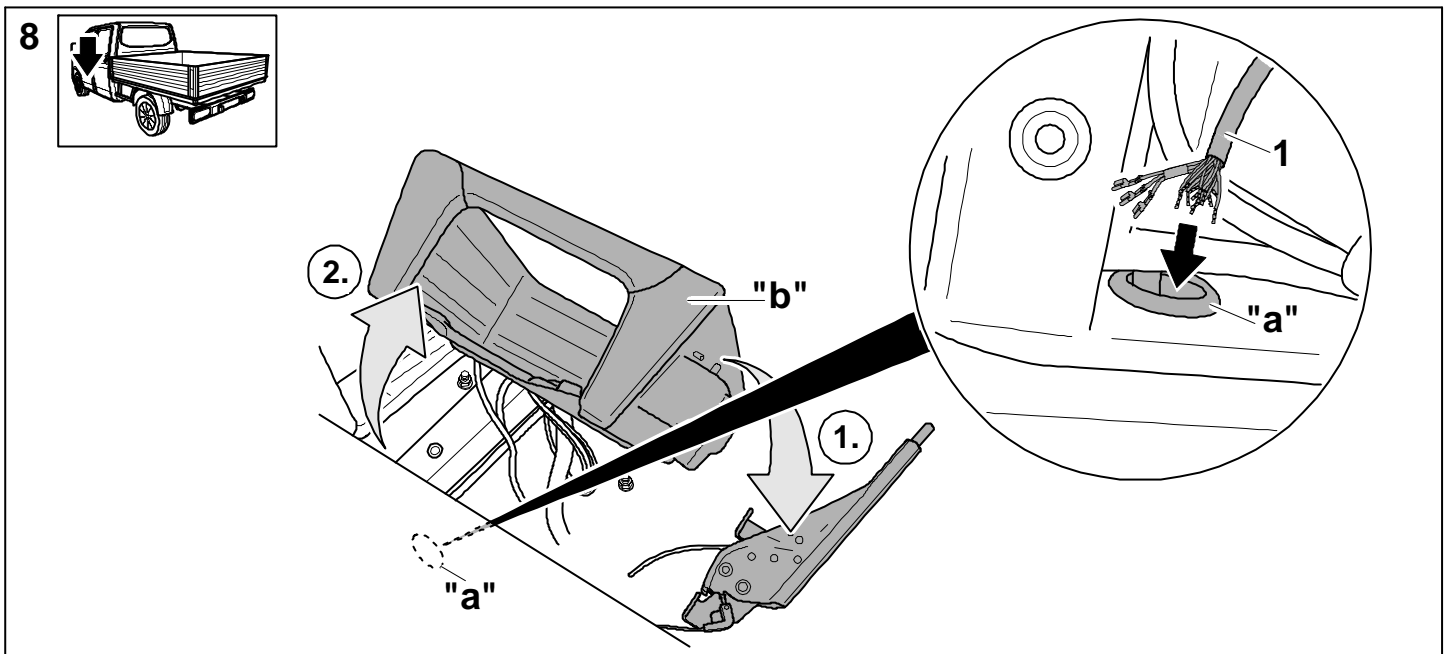
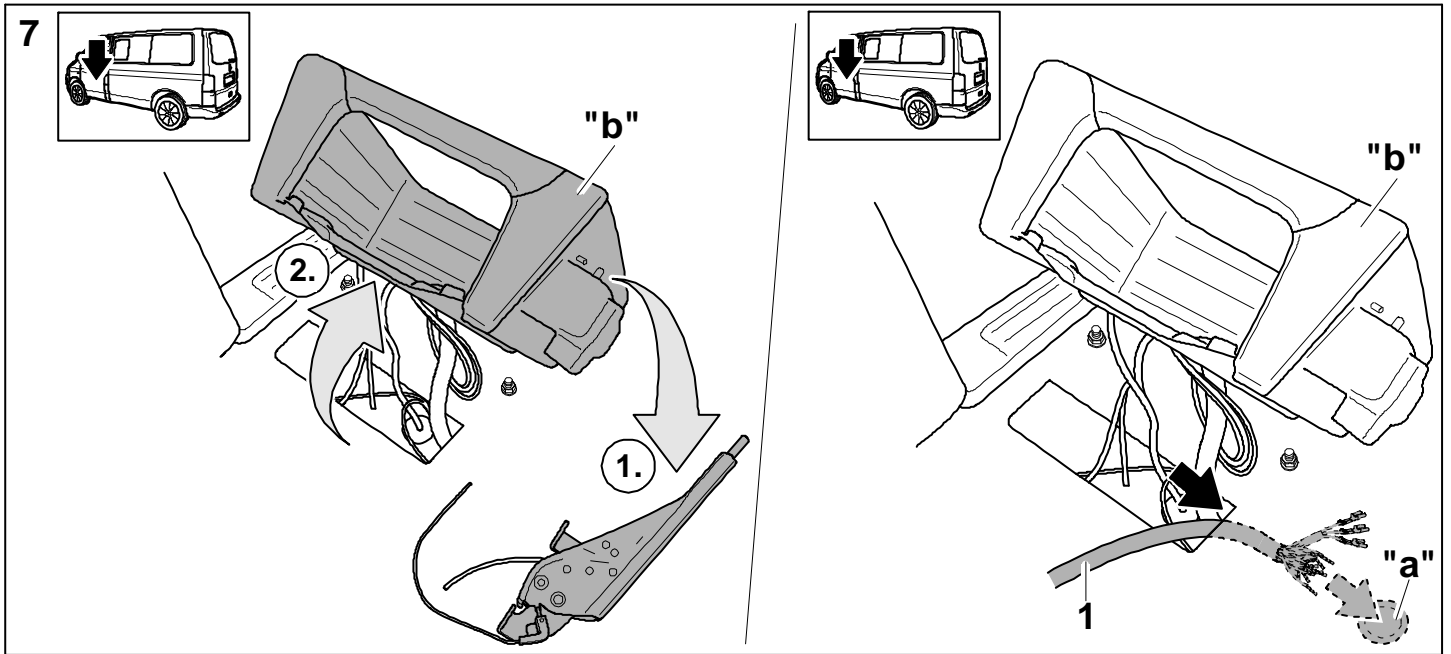

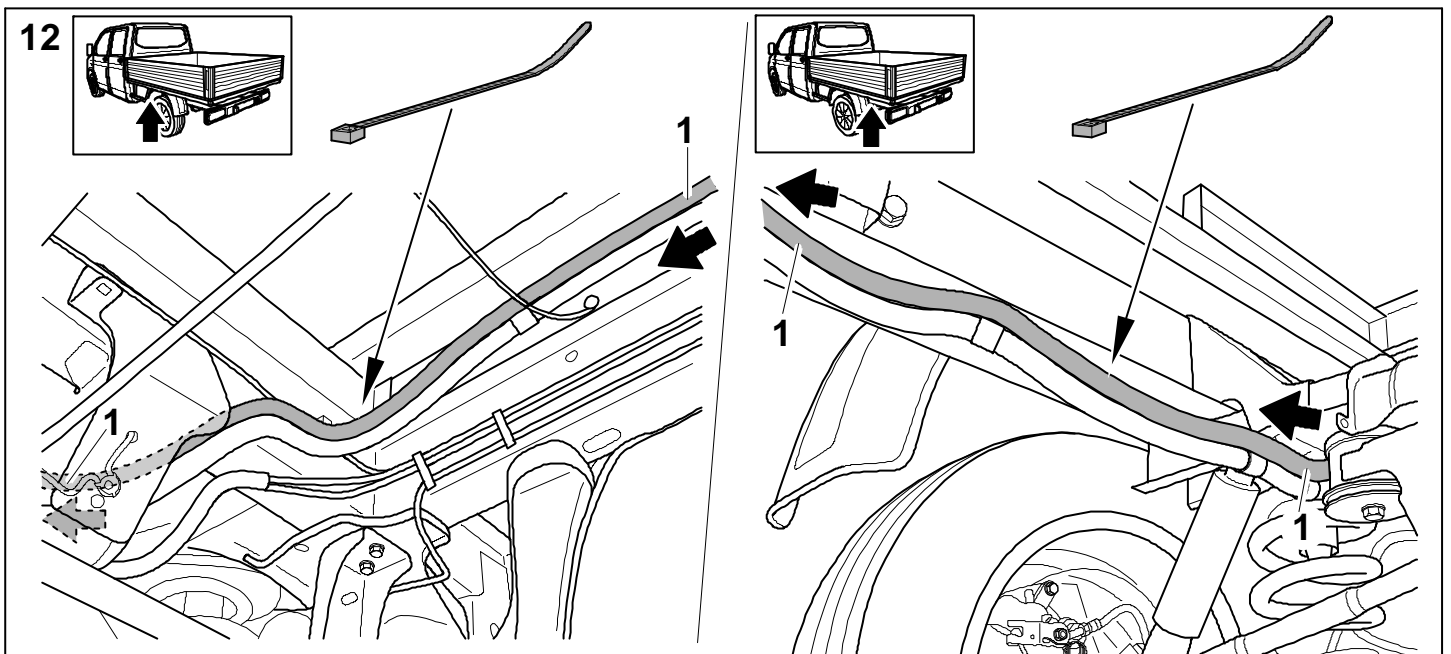
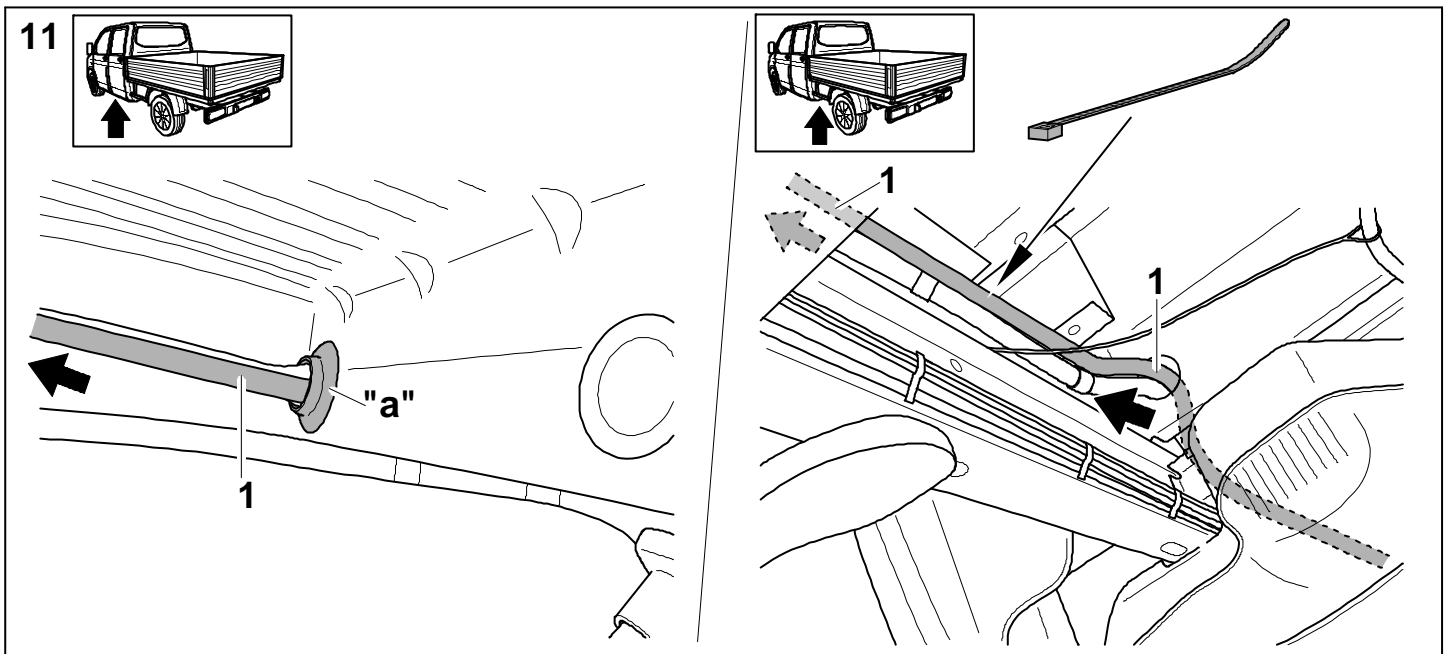
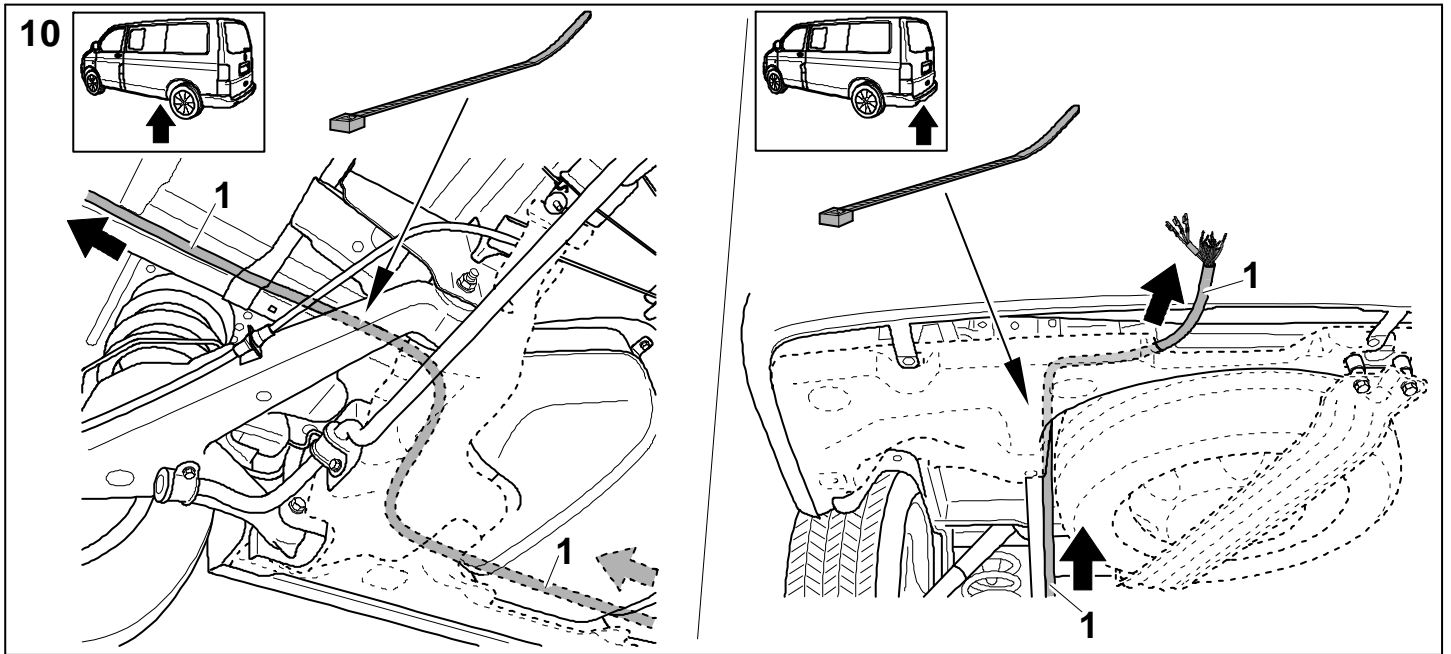

13

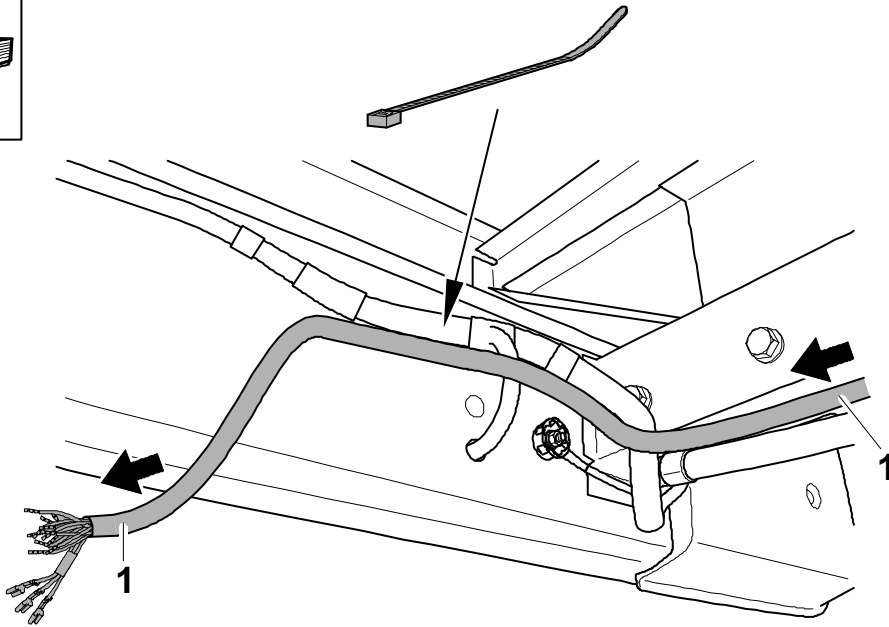
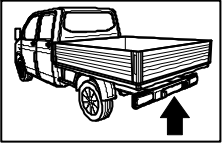

14

3x M5x35

3x M5

3x B5

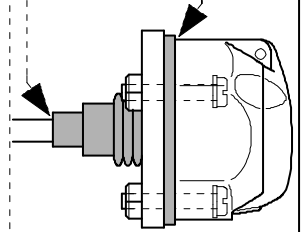
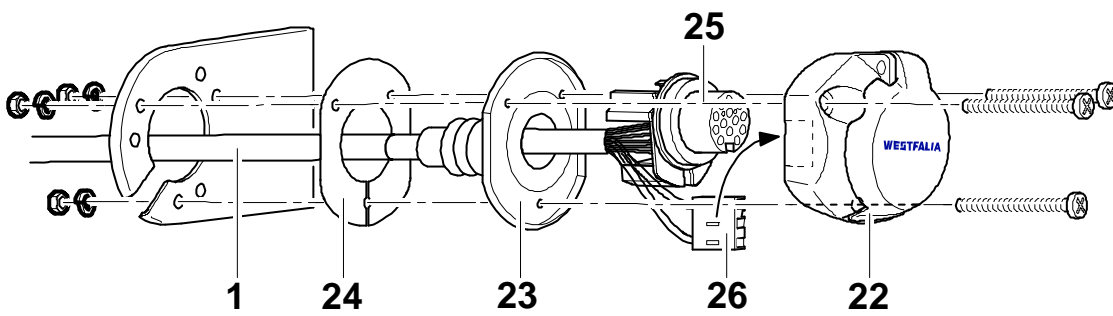
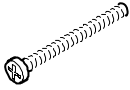

15

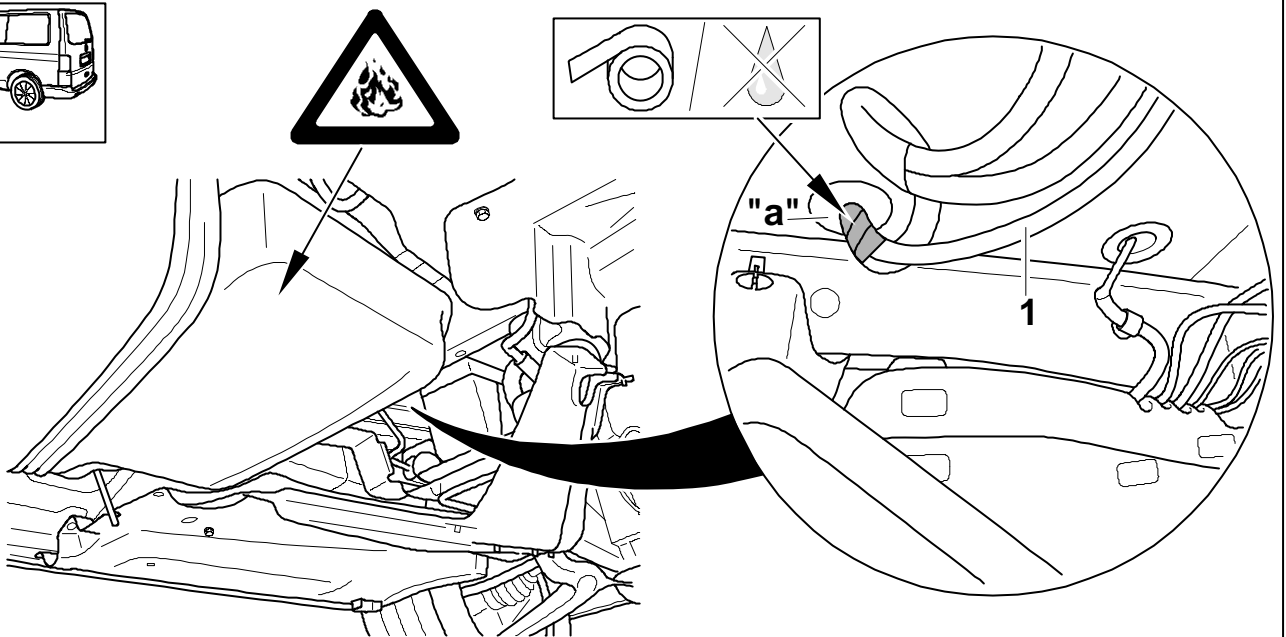
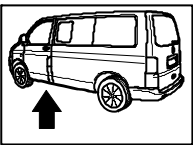

16

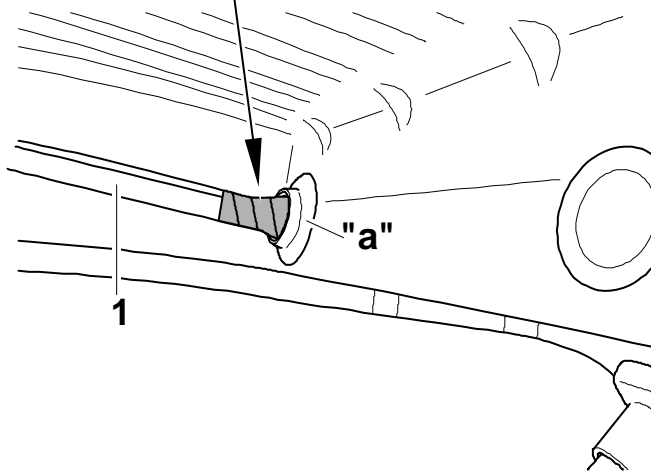
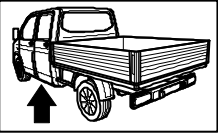

17

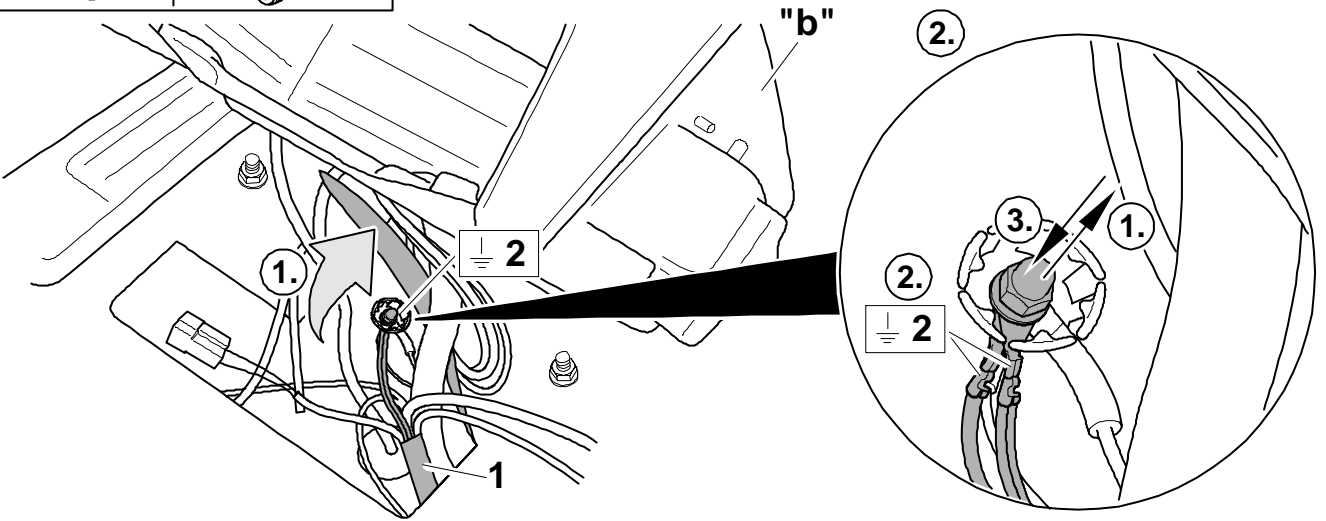

18

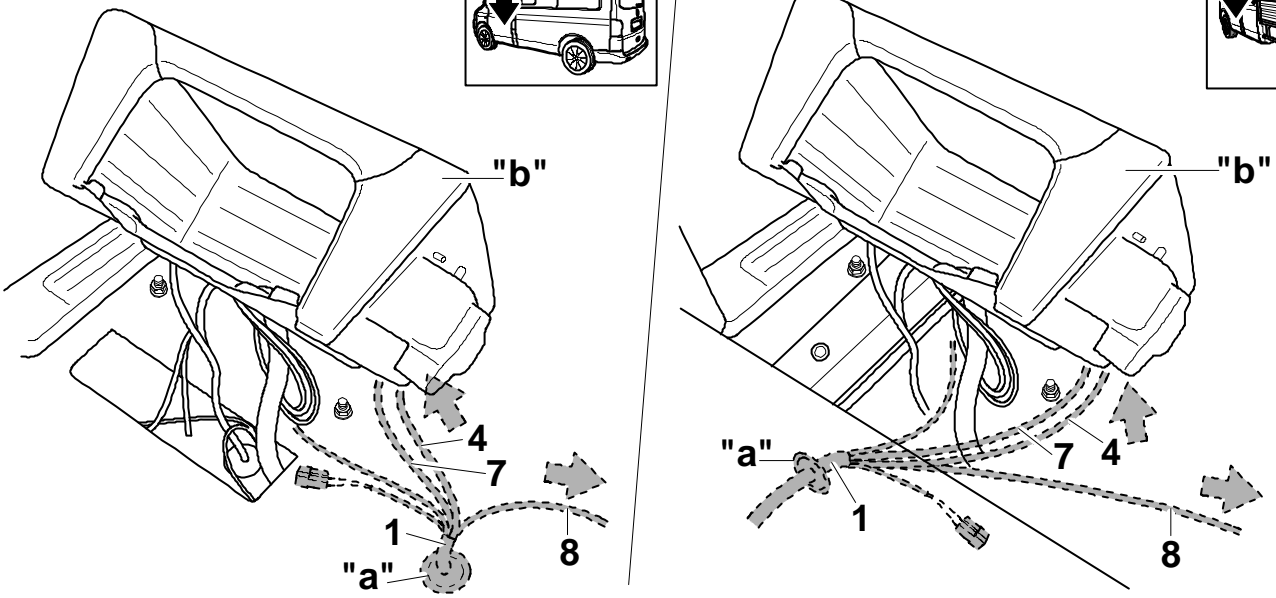
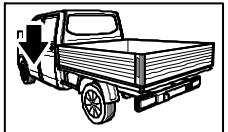
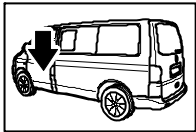

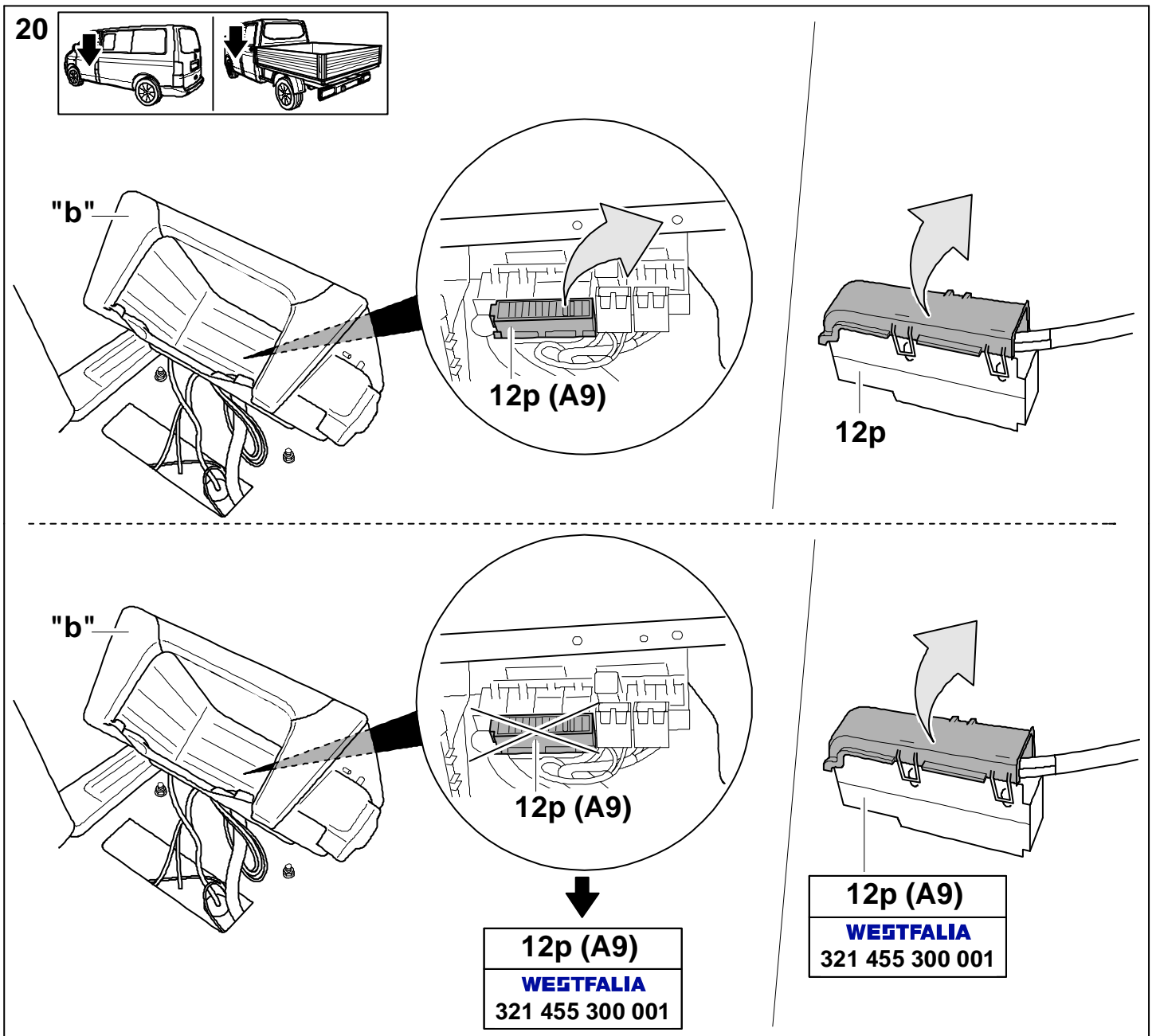
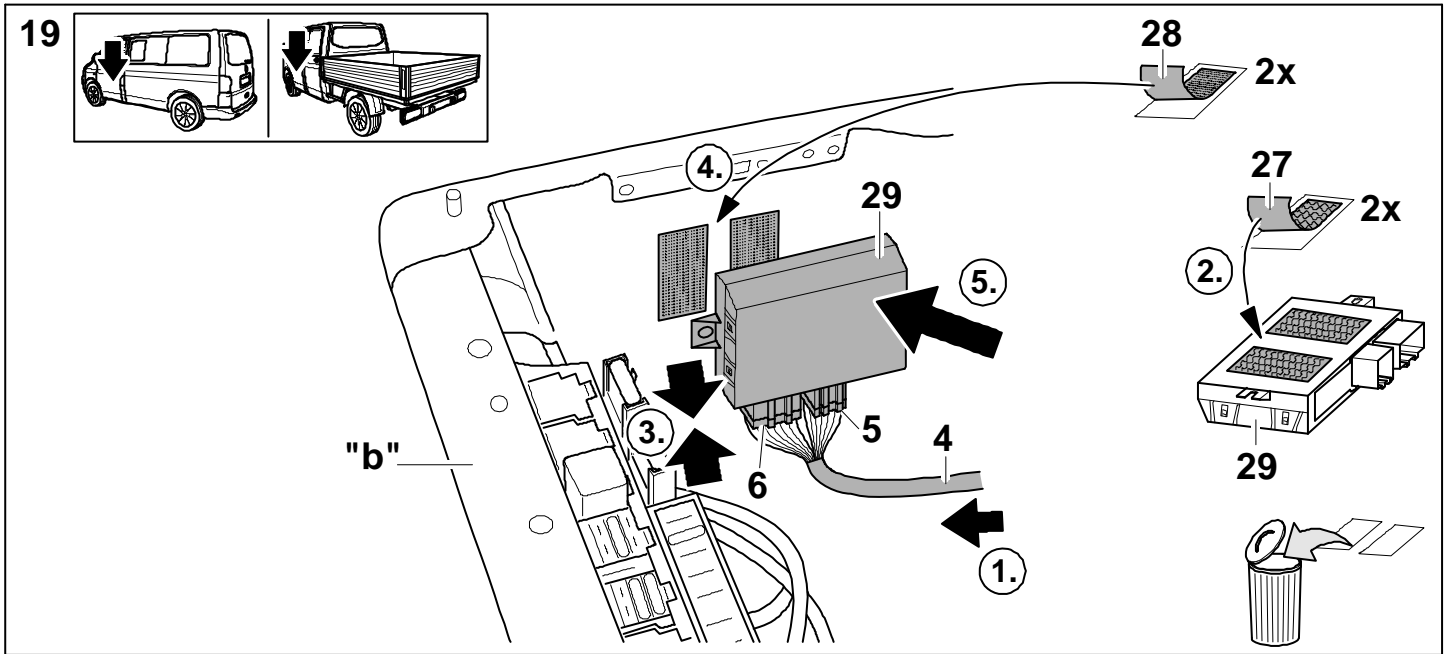

21

rd → Pin 4  
 rd/bk → Pin 5  
 rd/bu → Pin 6

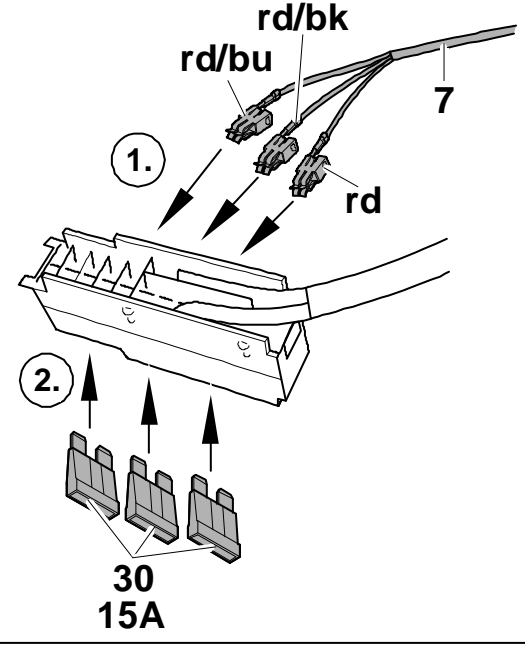
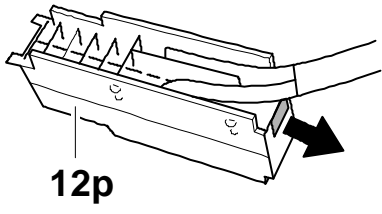

22

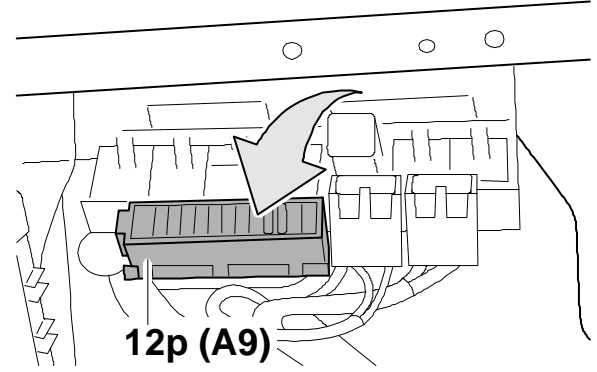
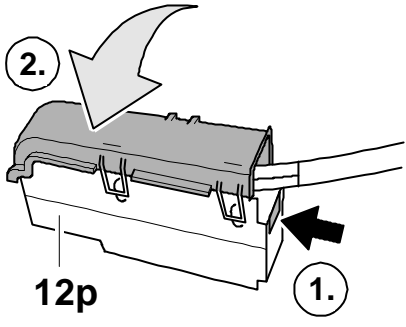
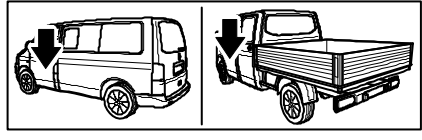

23

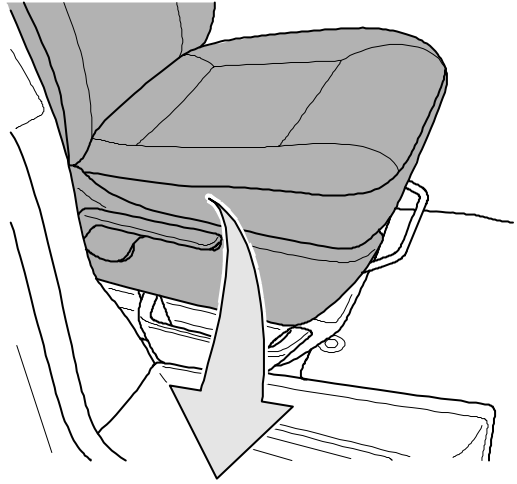
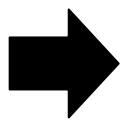
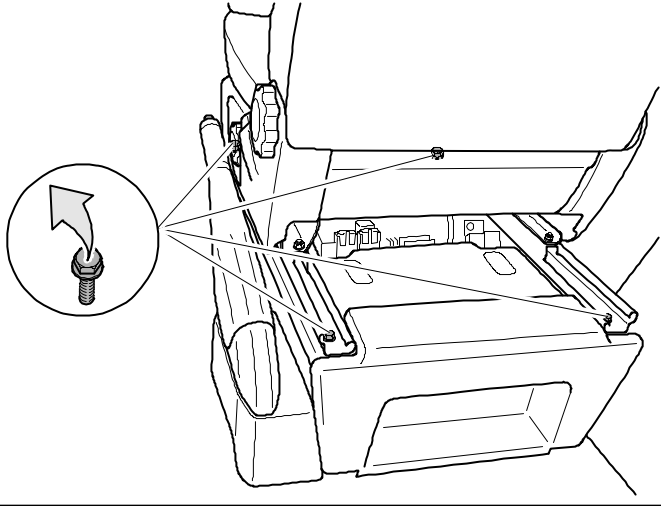
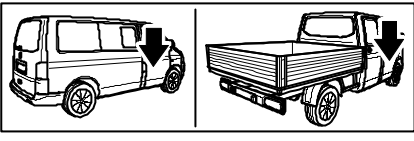

24

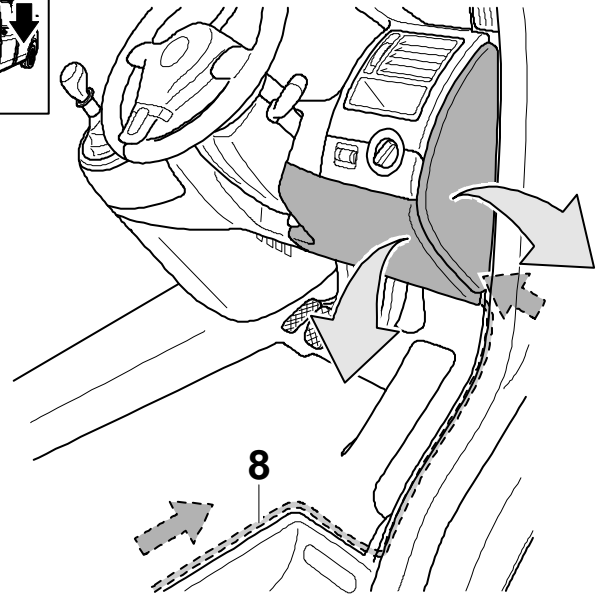
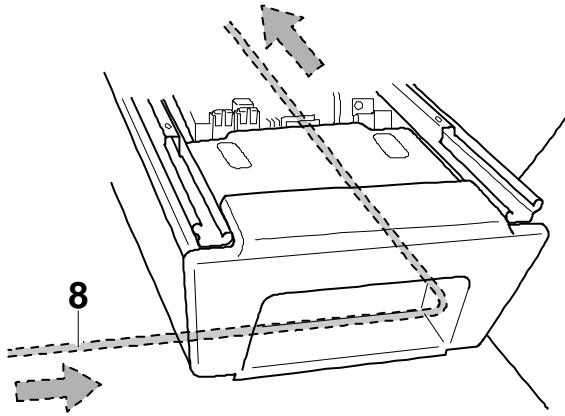
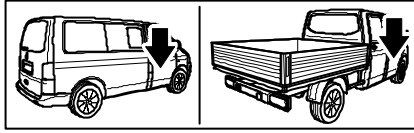

25

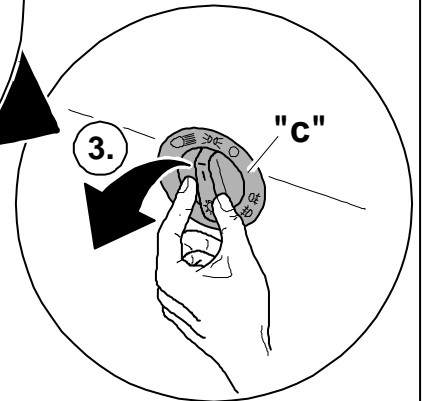
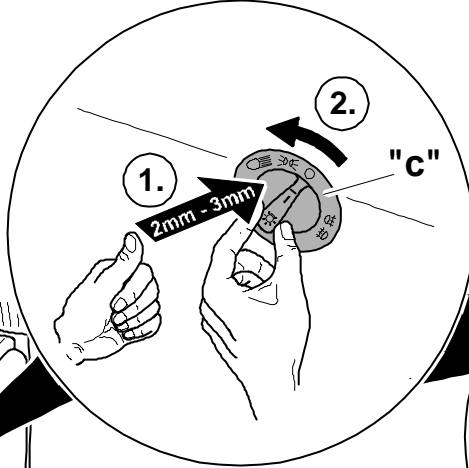
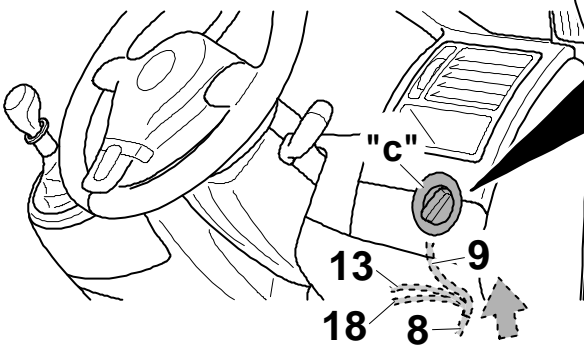
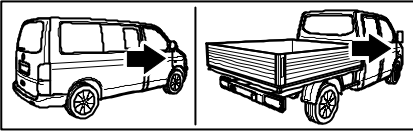

26



→ 27a 27b 29 →

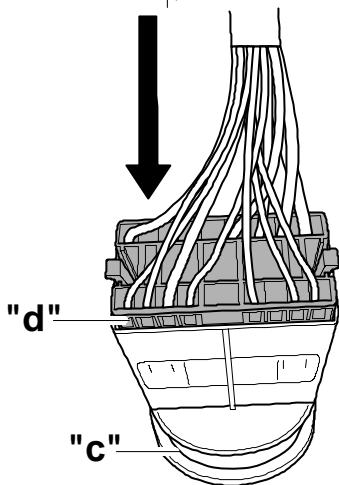

→ 28 29 →

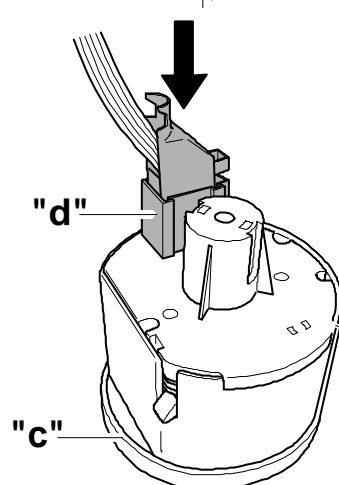



27a

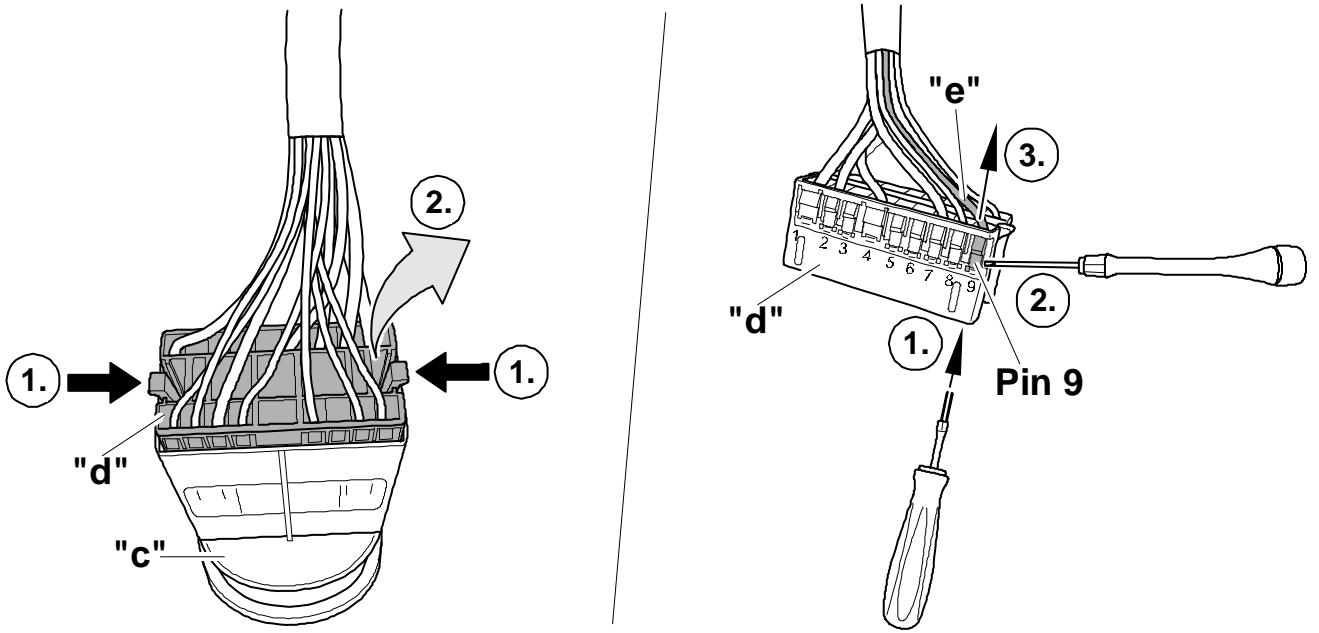

27b

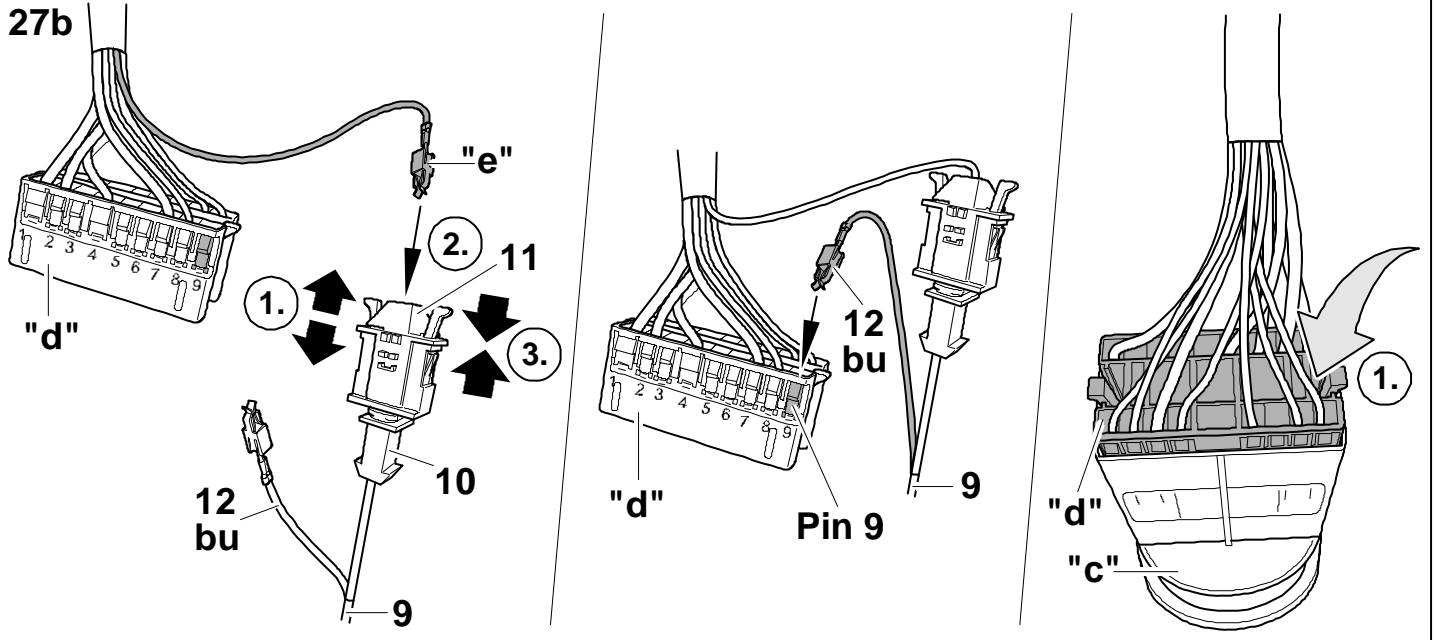

28

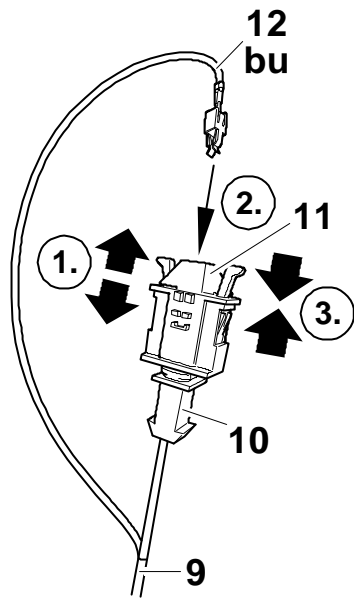

29

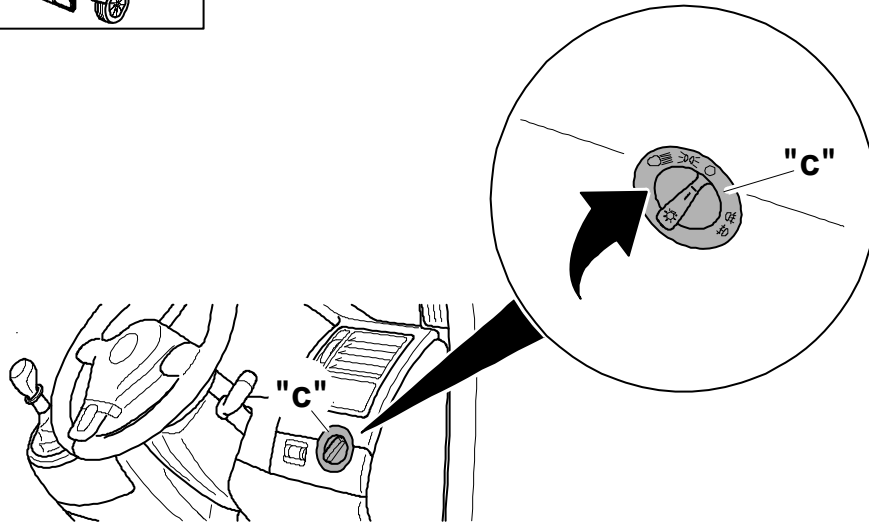
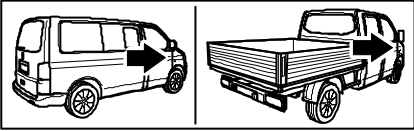

30

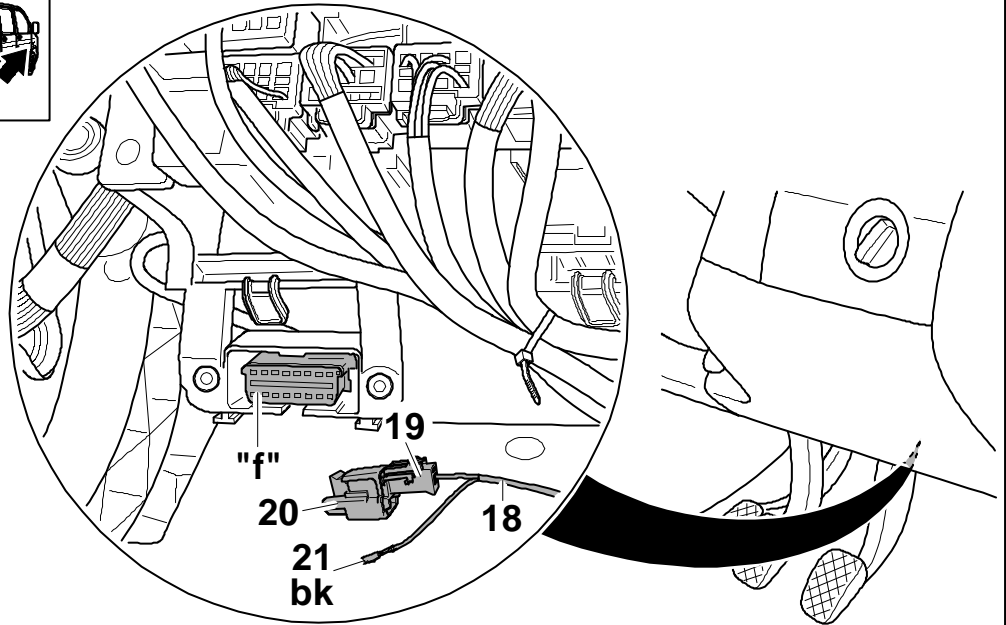
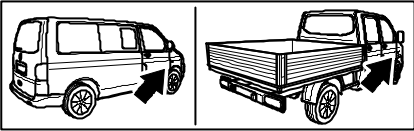

31

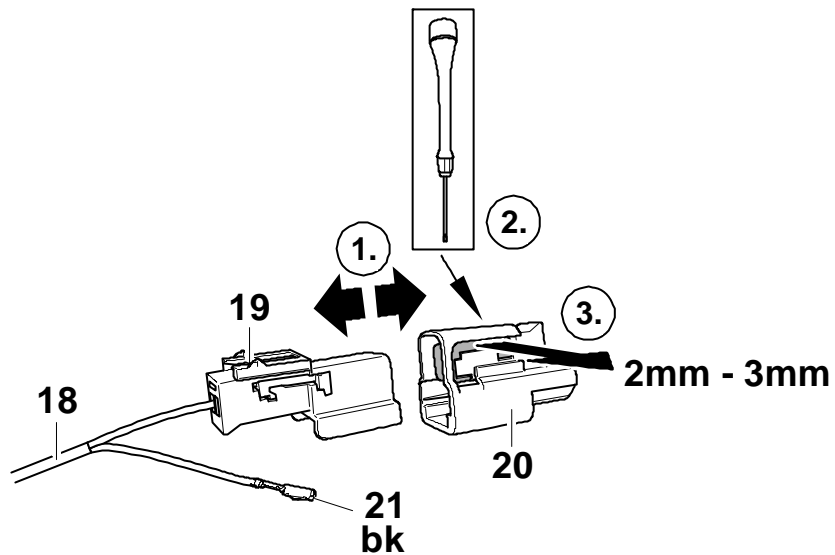

32

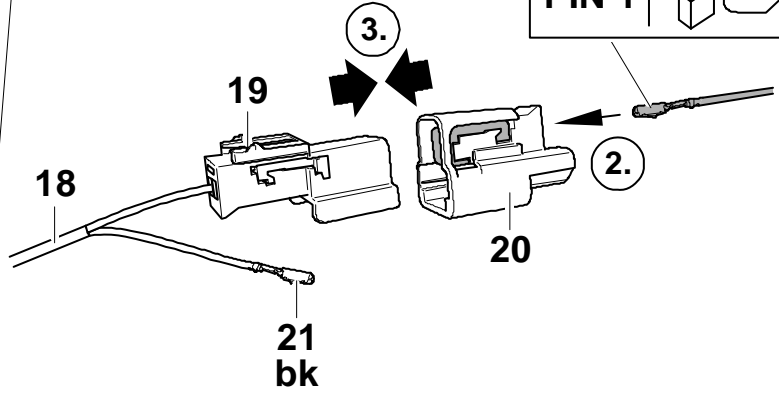
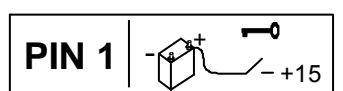
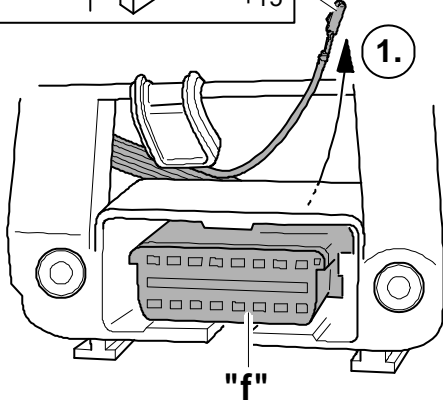
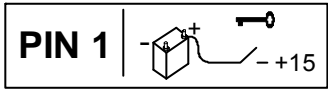
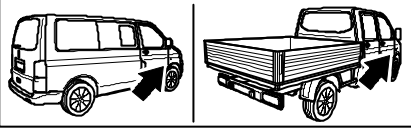

33

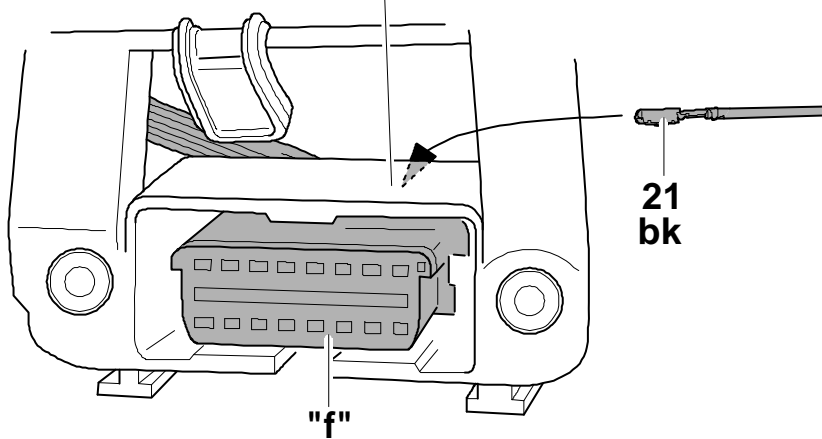
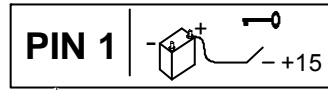
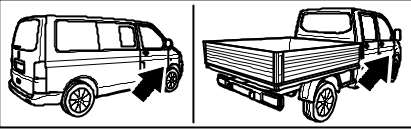

34

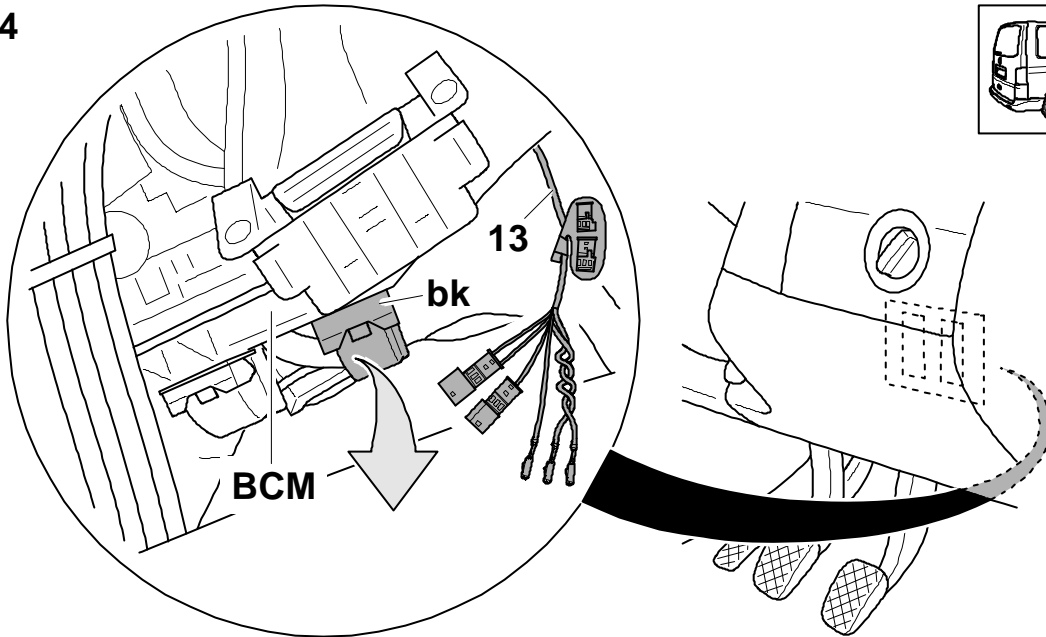
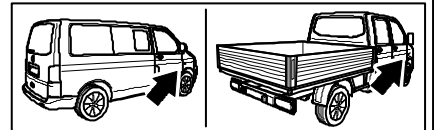

35

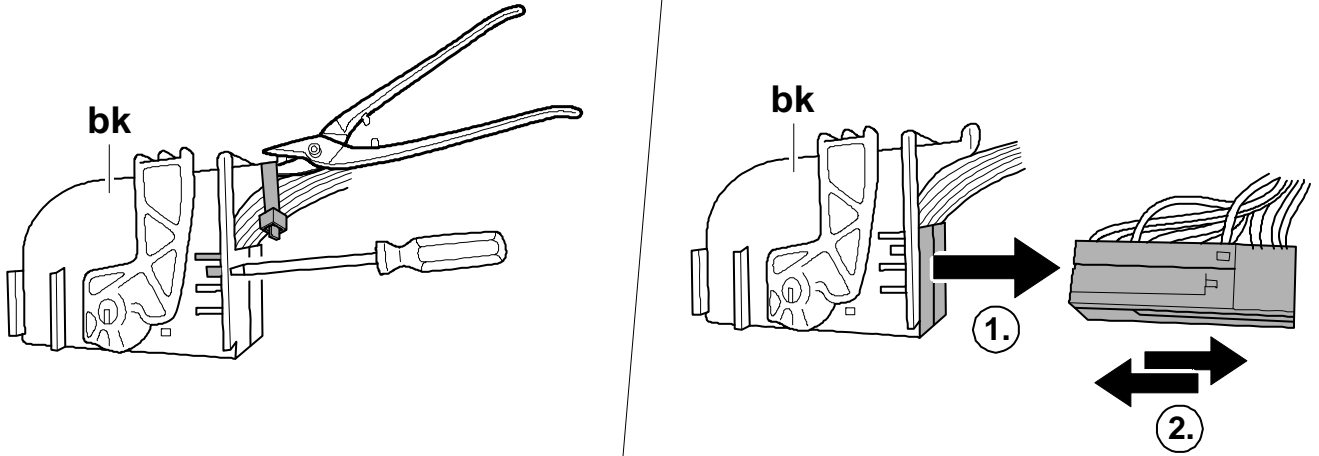

36

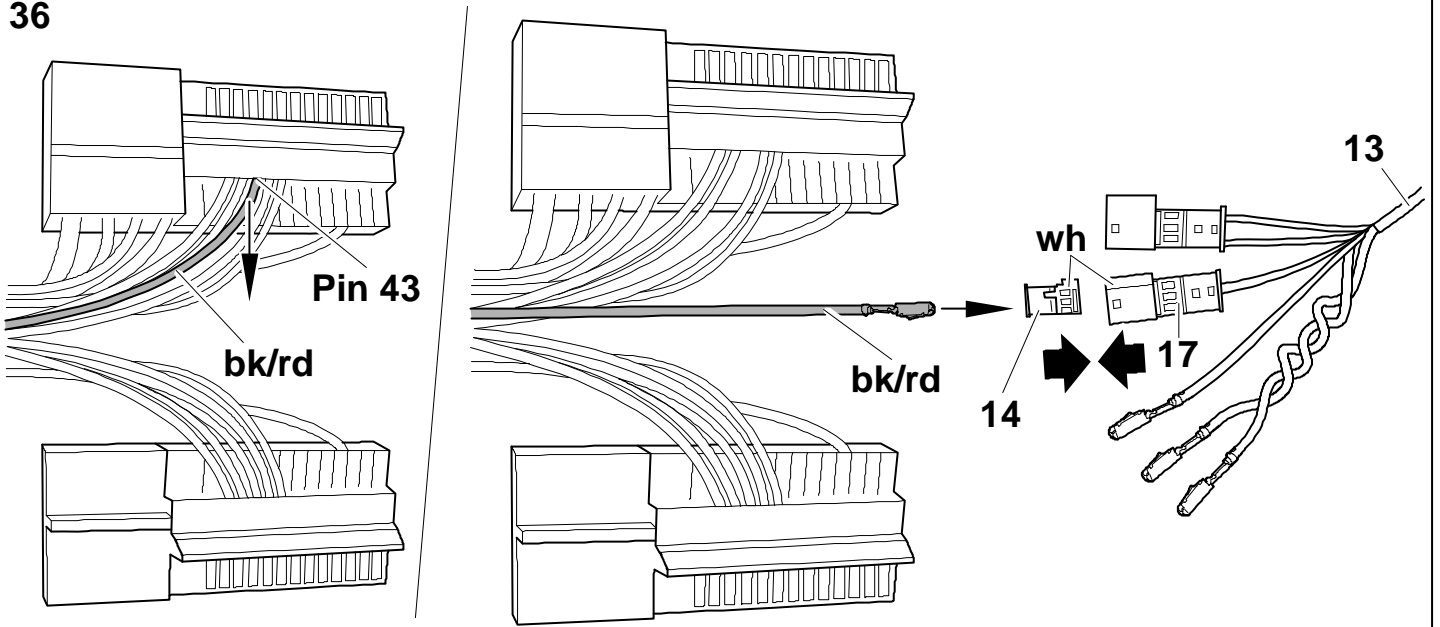

37

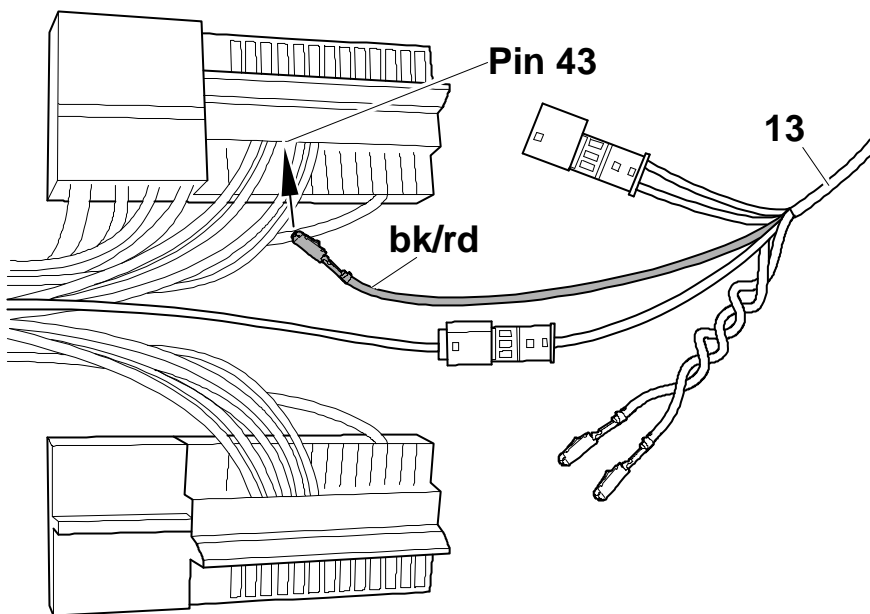

38

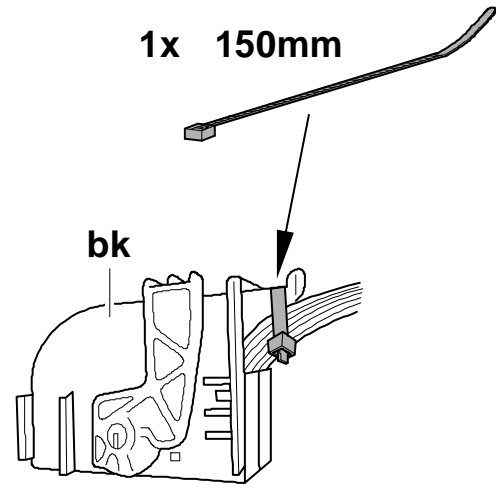
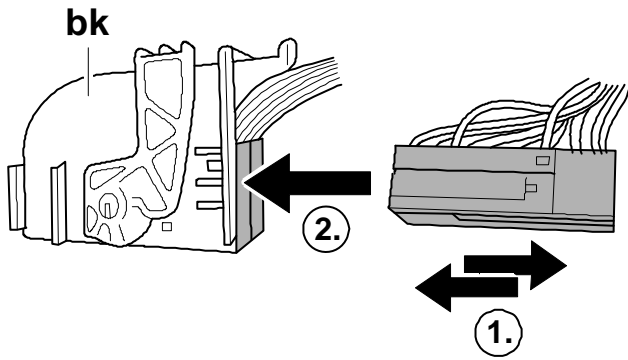

39

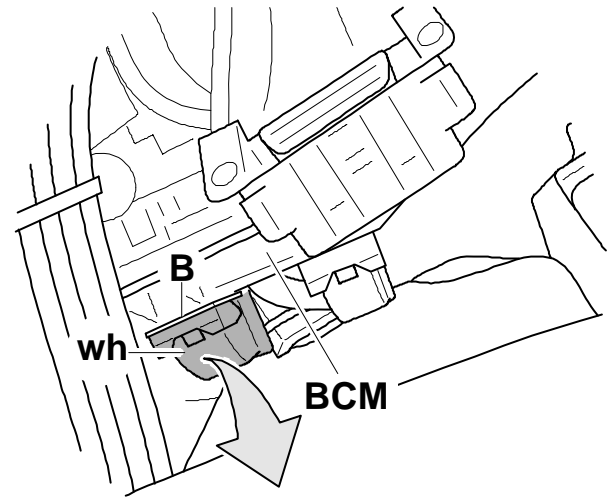
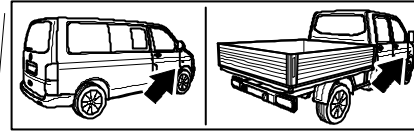
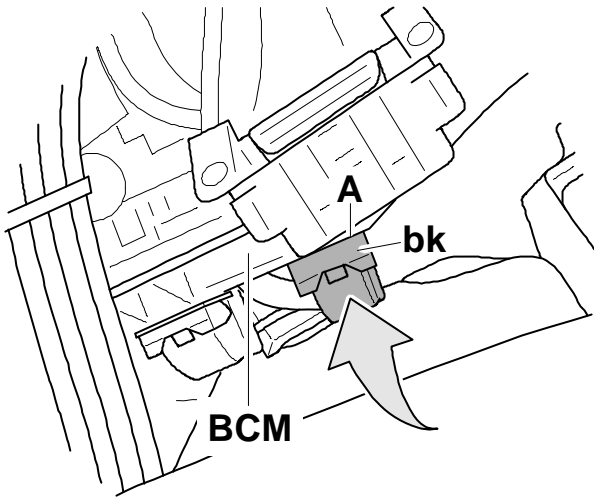
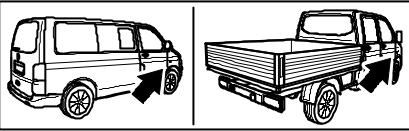

40

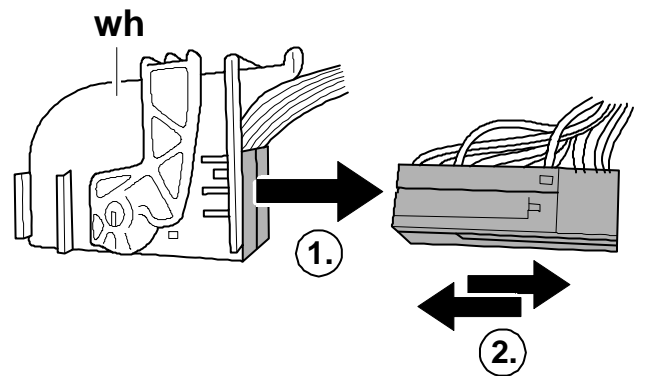
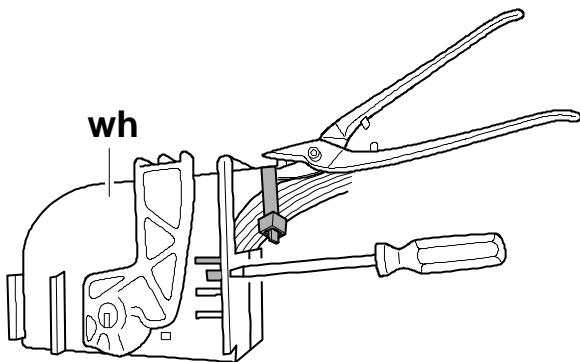

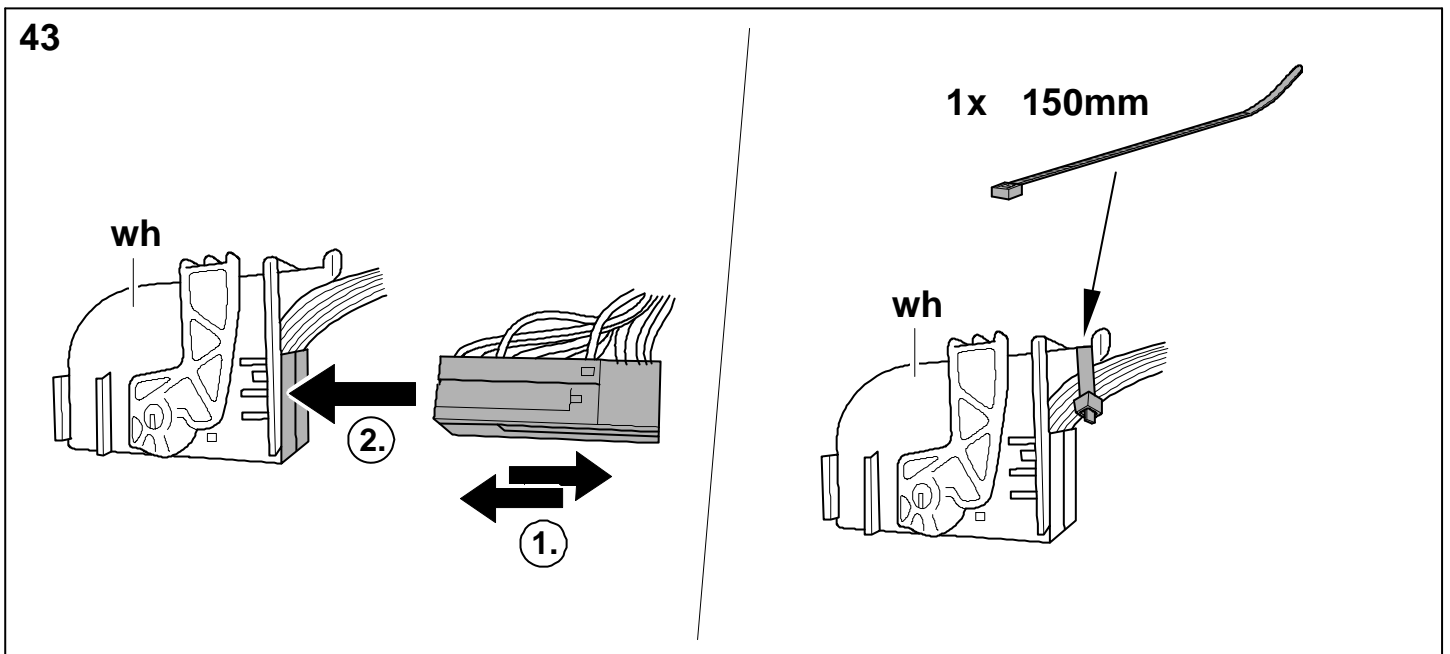
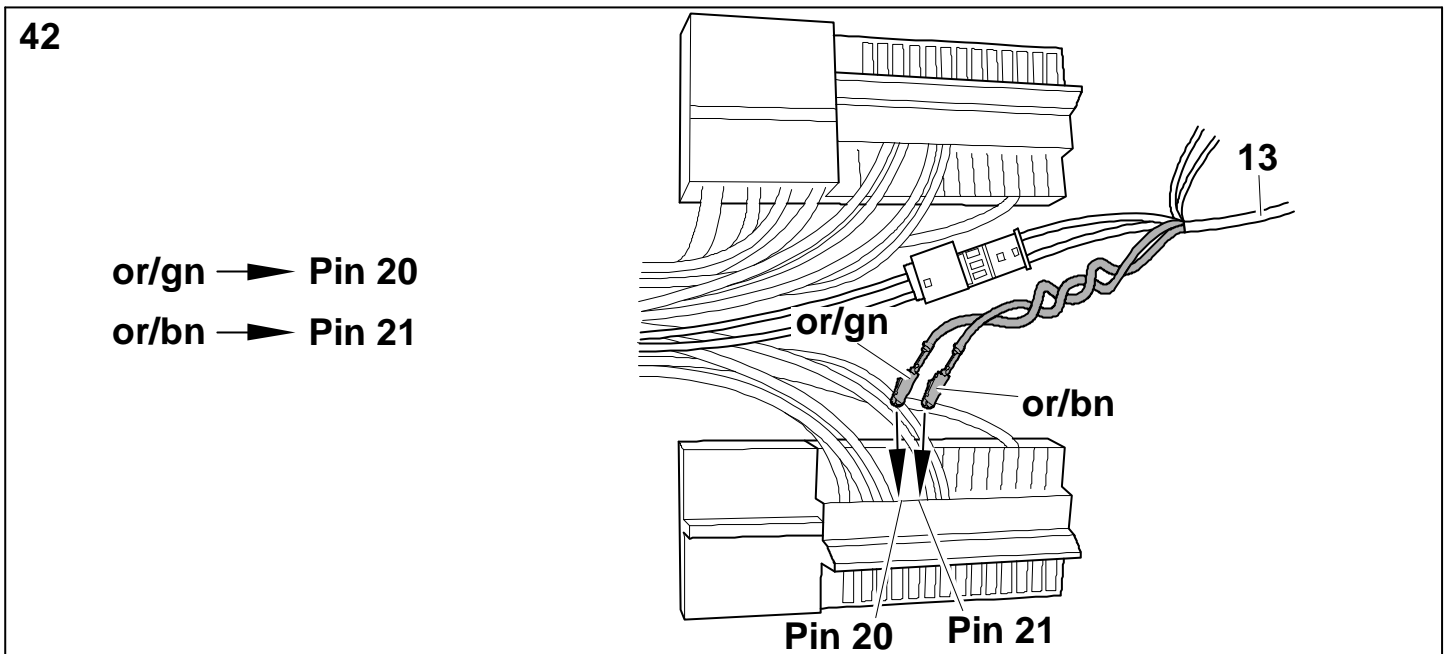
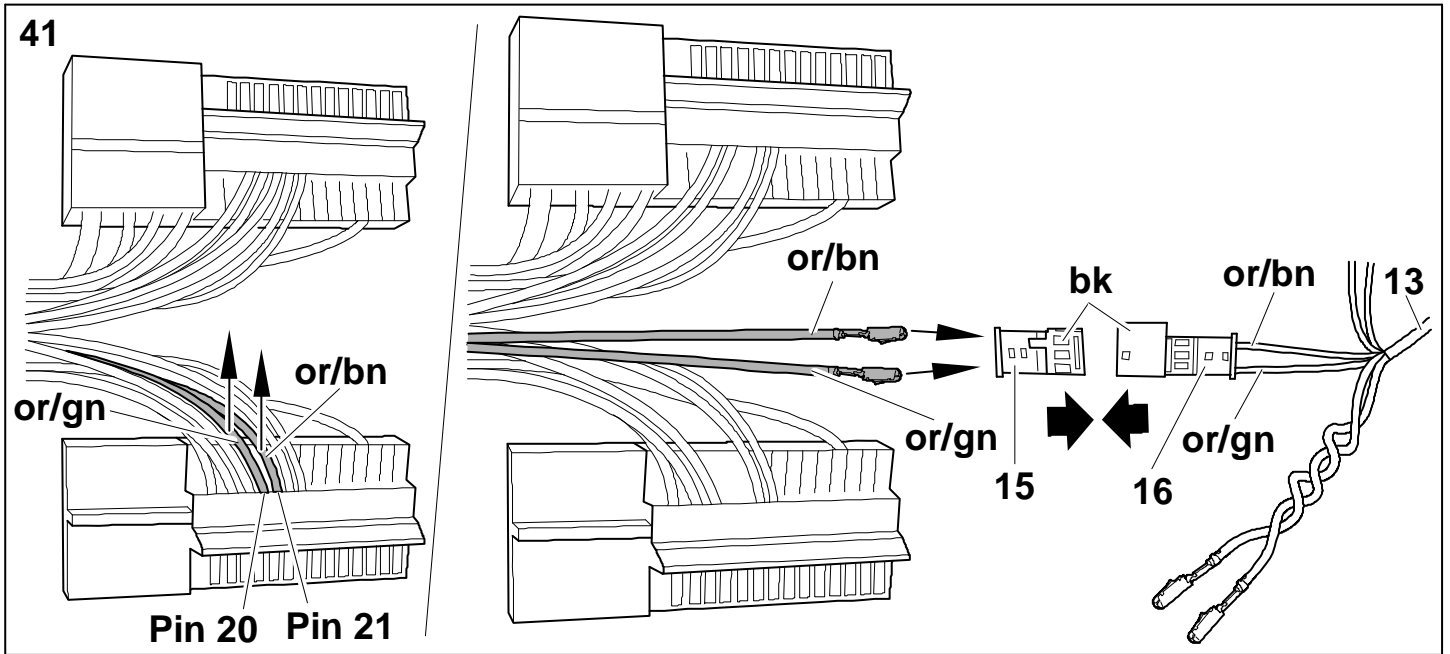

44

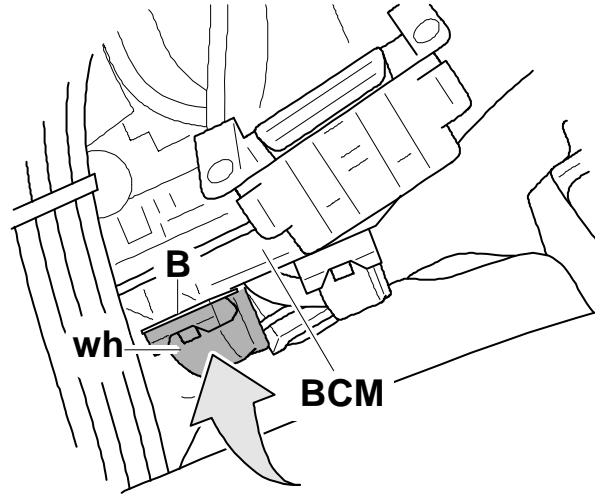
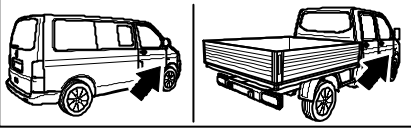

45

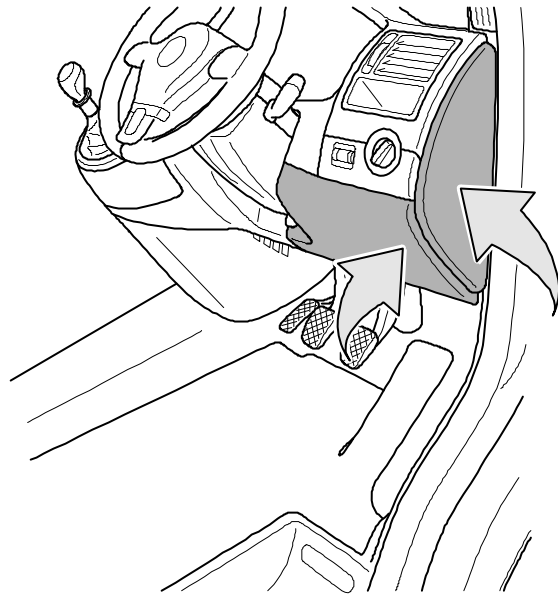
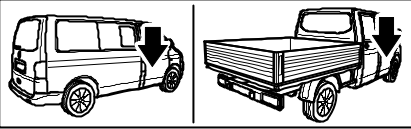

46

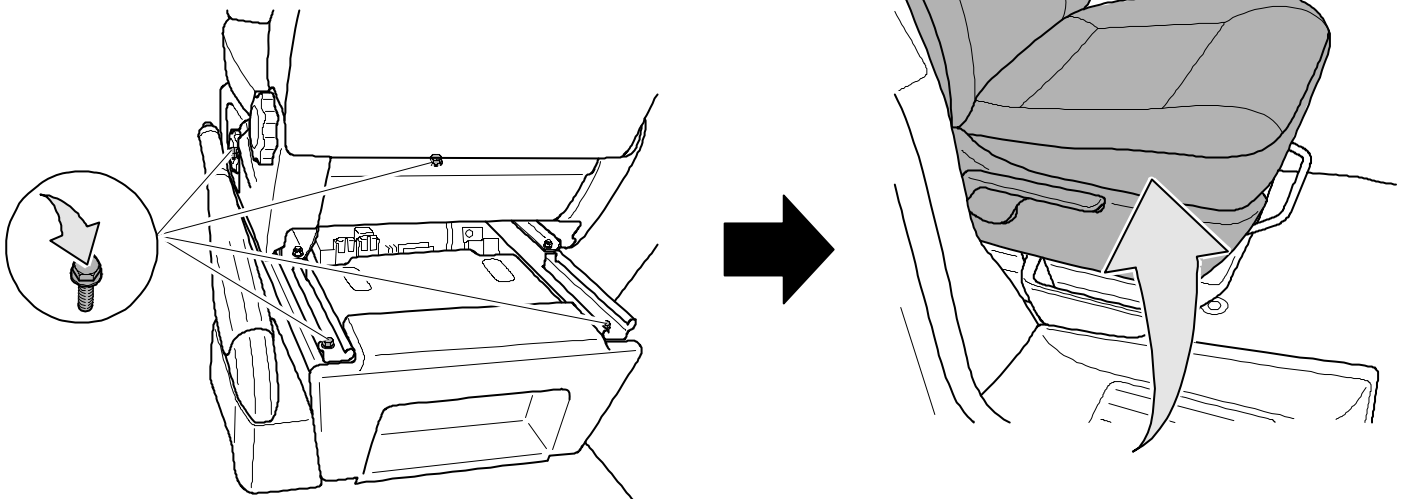
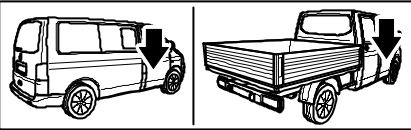

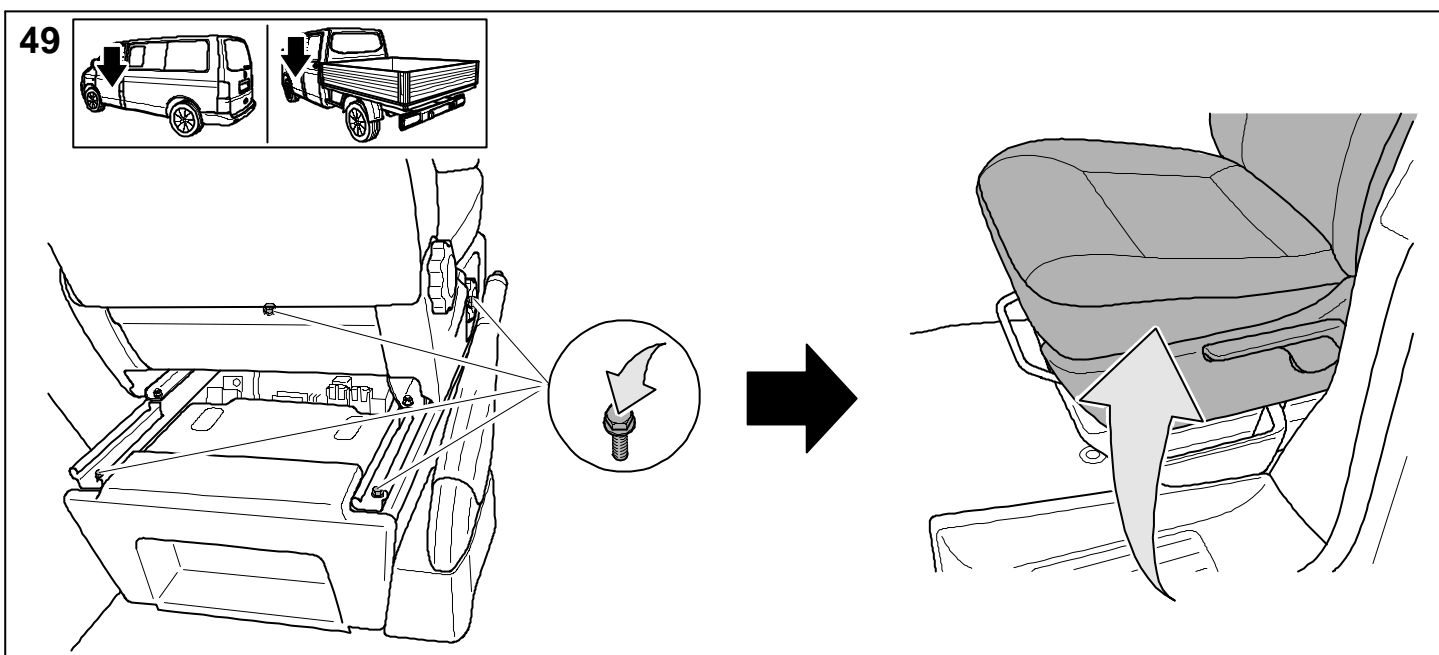
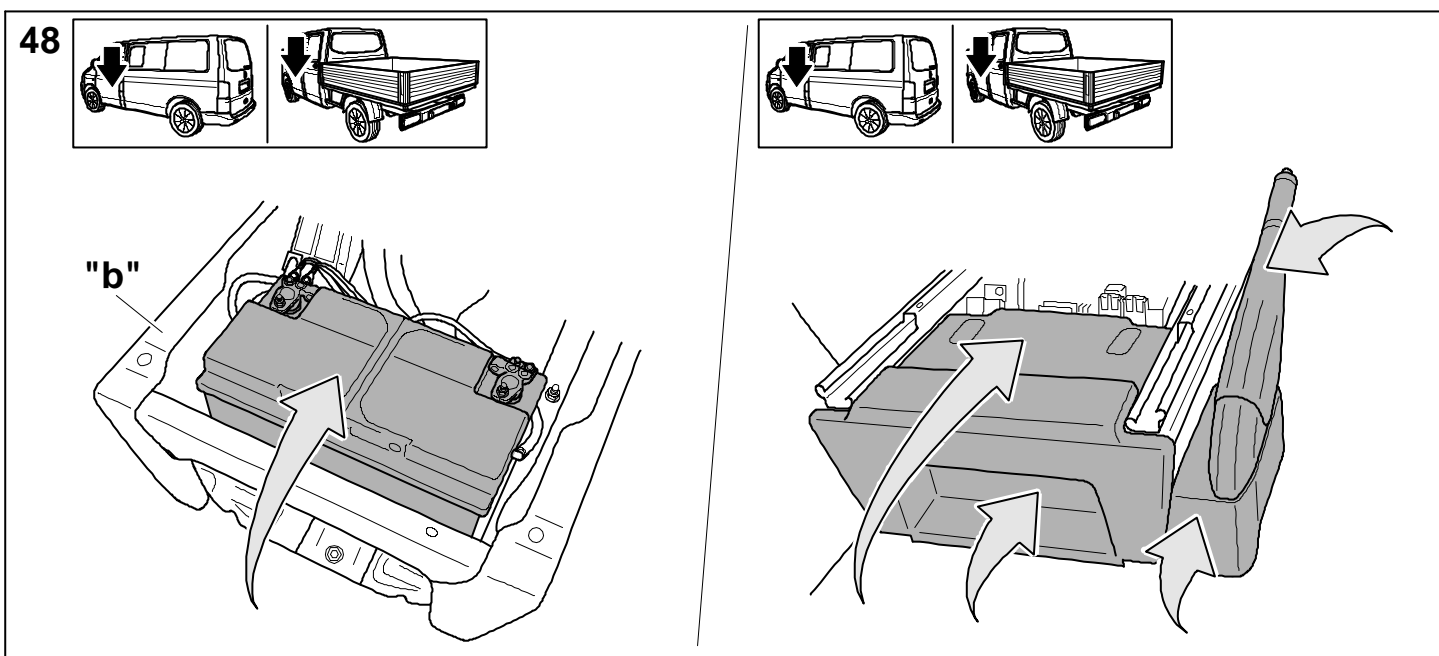
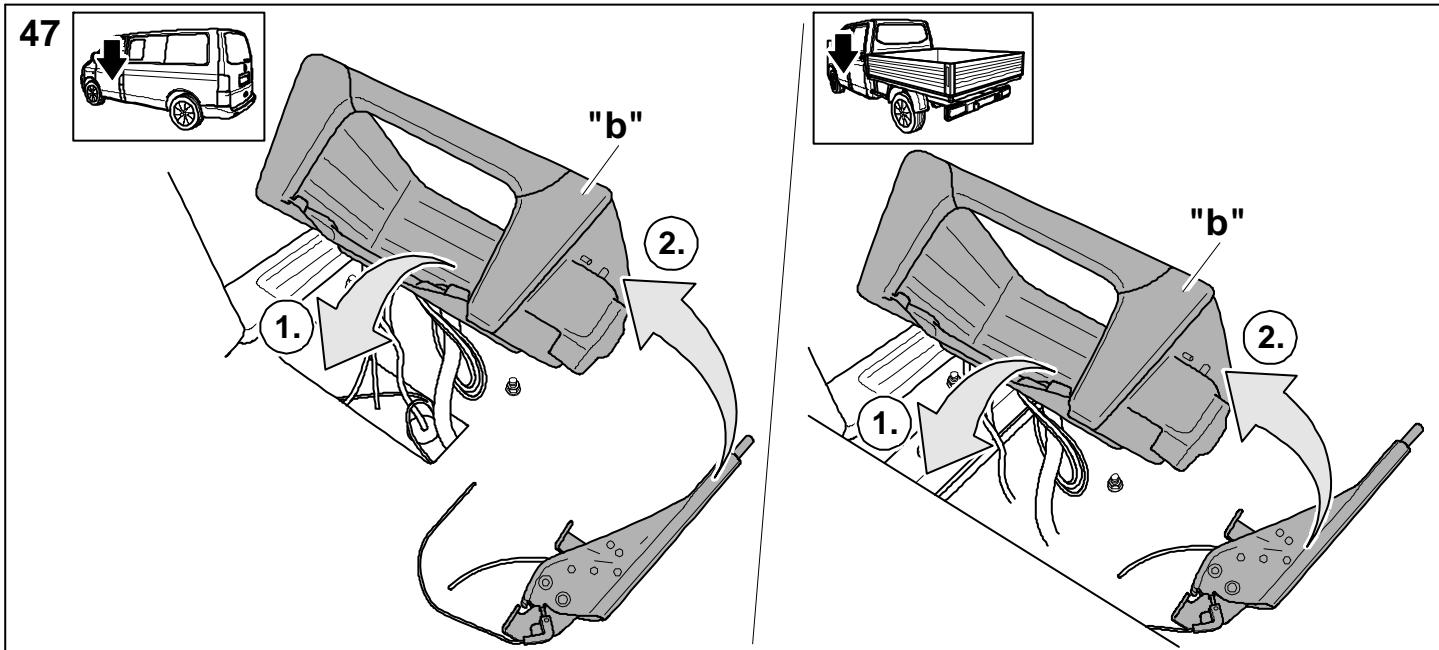



50

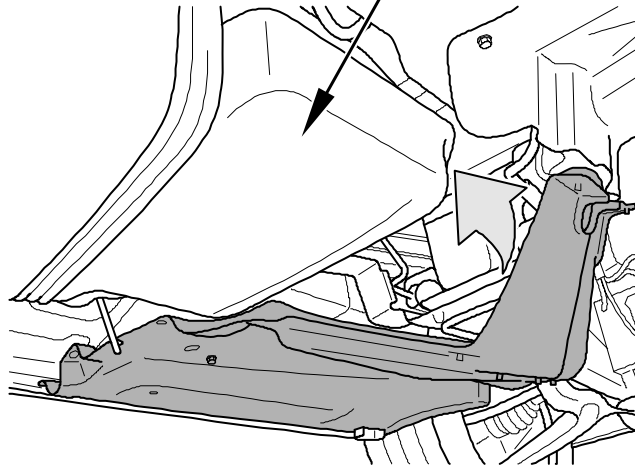
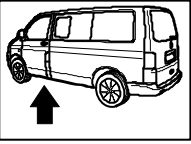

51

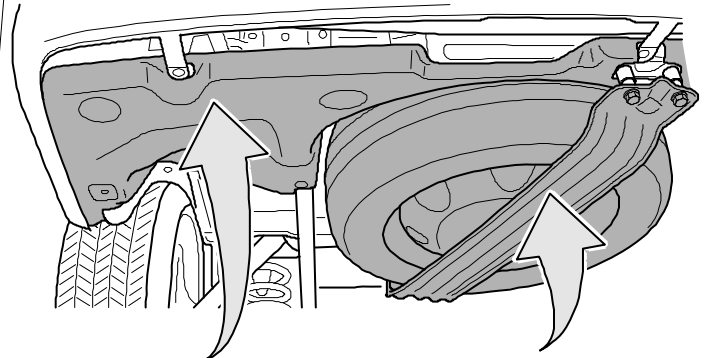
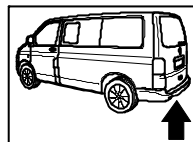
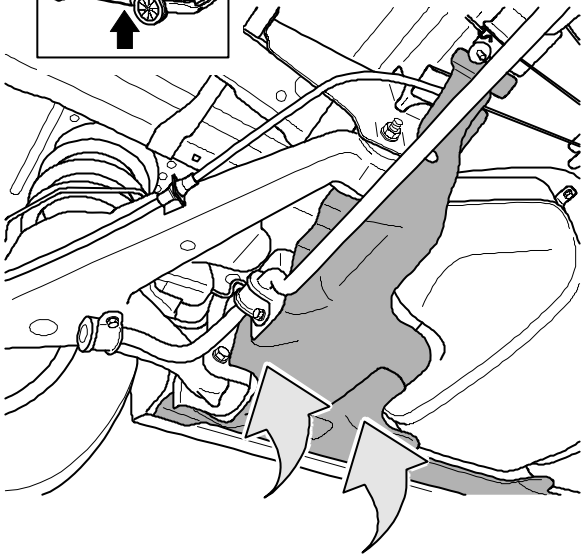
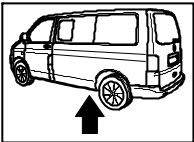

52

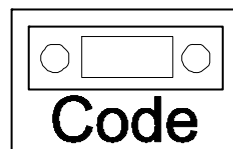
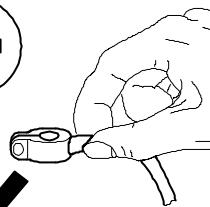
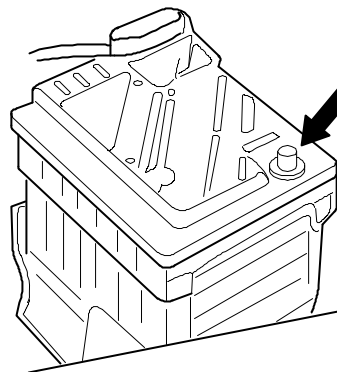
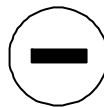

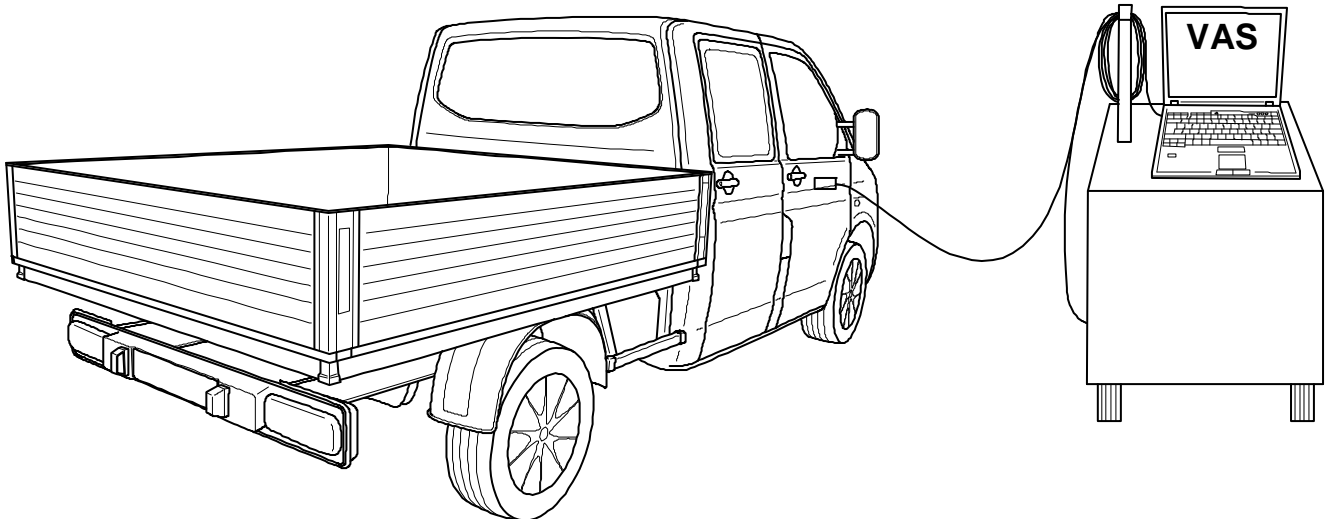
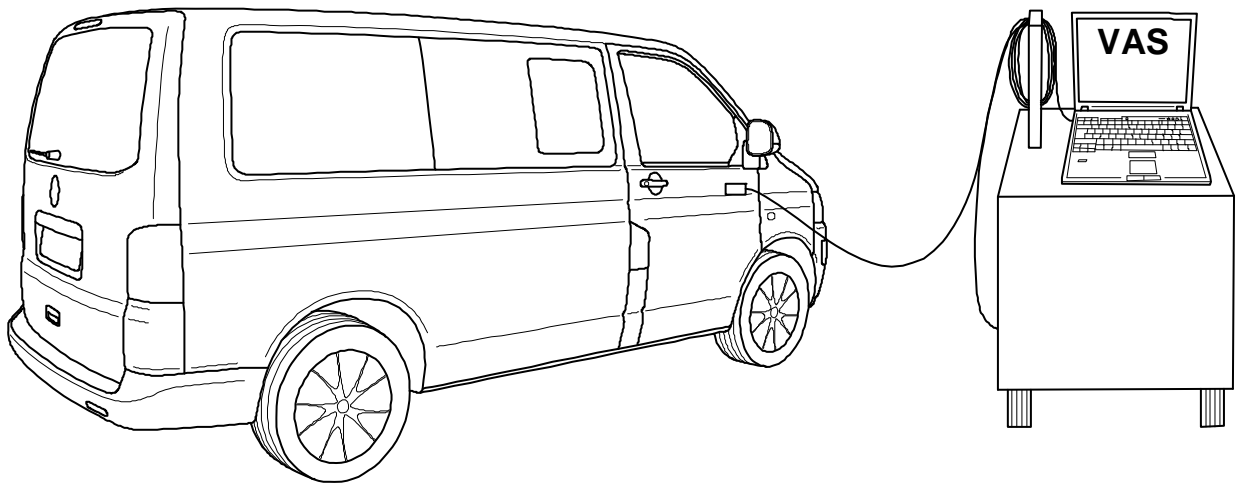

- GB**
1. The vehicle's gateway has to be coded as follows using a service tester to extend its functionality to the use of a towing hitch:
    - Address word "19", diagnosis interface for data bus.
      - Select function 008 coding (service \$22).
        - Select function 008.02 coding.
          - Select address word „69“, trailer function.
            - Change to „Coded“.
              - Continue the coding according to the menu.
  2. For vehicles fitted with parking assistance II or parking steering assistant, code the control unit using the VAS tester via "Guided trouble shooting" to "with a towing hitch".
  3. Finally, as at the beginning, perform a system request regarding the "Guided error location" and delete error codes if necessary.

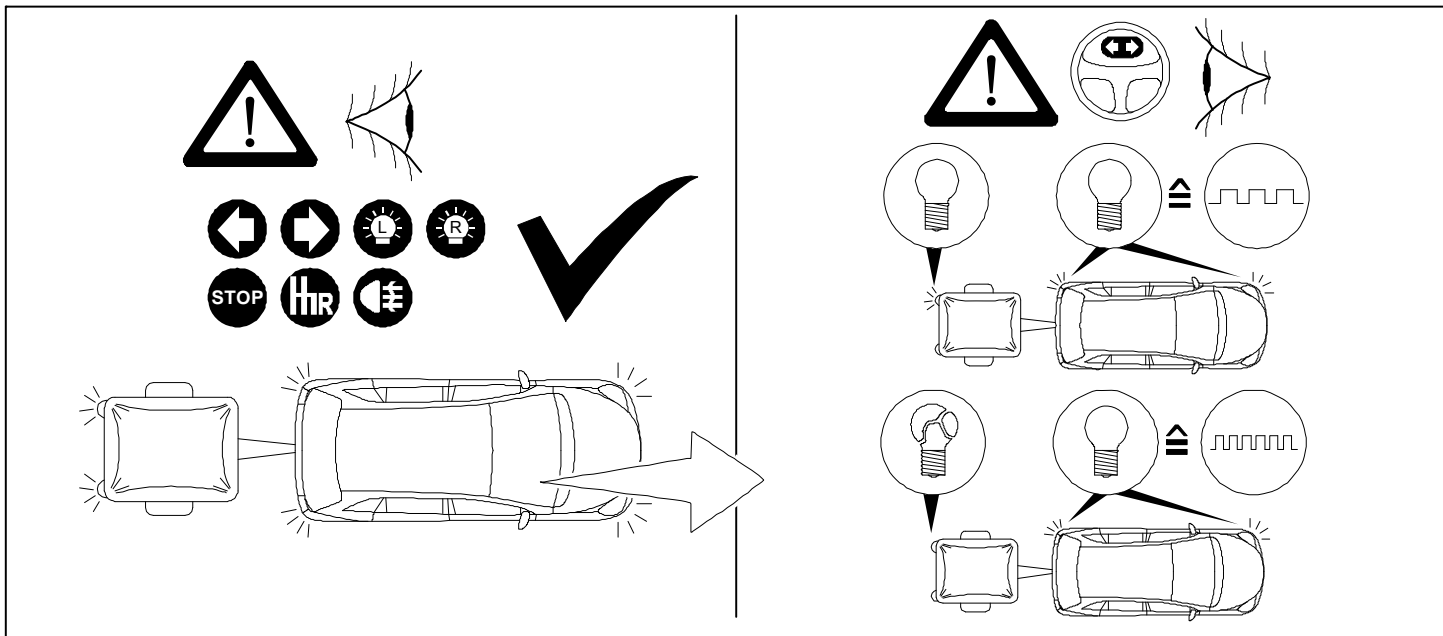

**WESTFALIA**

Trailer simulation for carcheck 7-pin and 13-pin

WA no.: 900 001 300 199

