

Part No. 29010504RC AUDI

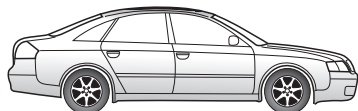

A6 Saloon

05/04 →

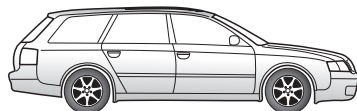

A6 Avant

03/05 →

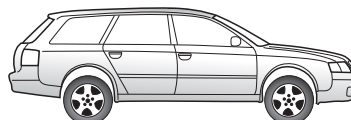

A6 Allroad Quattro 05/06 →

Electric wiring kit for towbars / 13-pin / 12 Volt / ISO 11446 Fitting instructions

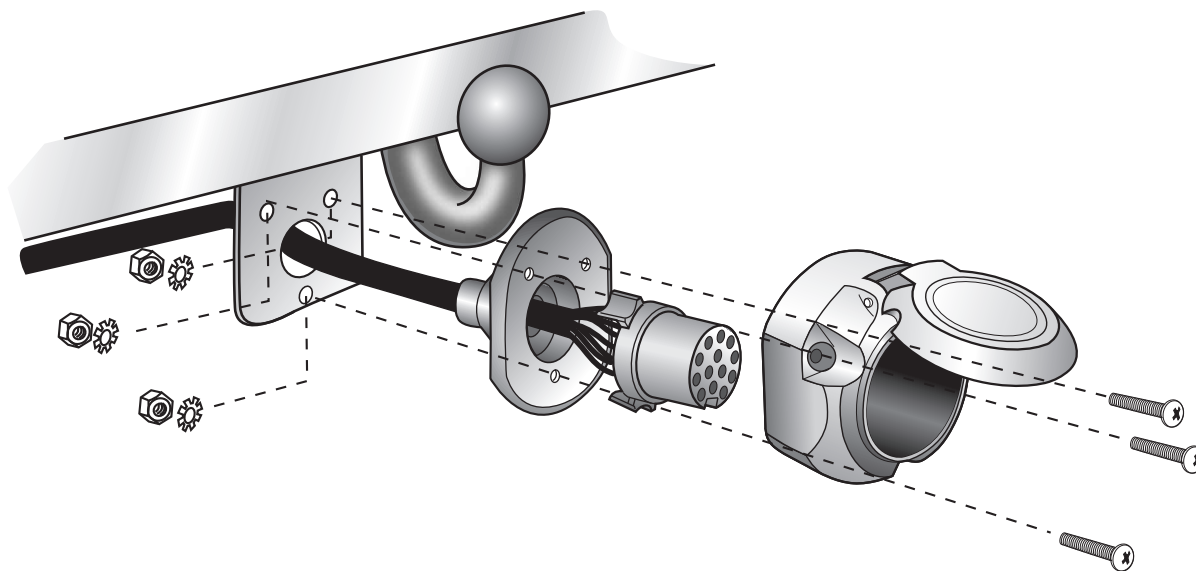

IMPORTANT!



Installation of the towing electrics kit must be undertaken by a specialist workshop or an appropriately qualified person. Before starting work, you must read the installation instructions through completely. After installing the towing electrics kit, the installation instructions should be kept with the vehicle service documentation.

All claims under the guarantee will lapse in case of improper use or modification of the towing electrics kit or any of its component parts. When driving without a trailer or load carrier, any adapter installed must be removed from the electrical socket. We reserve the right to alter the design, content or colour. We accept no liability for any errors in these instructions. All details and illustrations are non-binding.

In case of missing a rear fog lamp on the trailer, it should be retrofitted.

We accept no responsibility and give no guarantee for technical and electrical modifications made after the initial operation of the towing electrics kit by the vehicle manufacturer and which may lead, for example to malfunction of the trailer socket or its peripheries.

The trailer module is not diagnostics-capable. If the manufacturer's diagnostics processes or software-supported test mechanisms generate error reports directly or indirectly linked with trailer operation, the trailer module must be disconnected from the leads to the trailer socket and a new diagnostic process initiated.

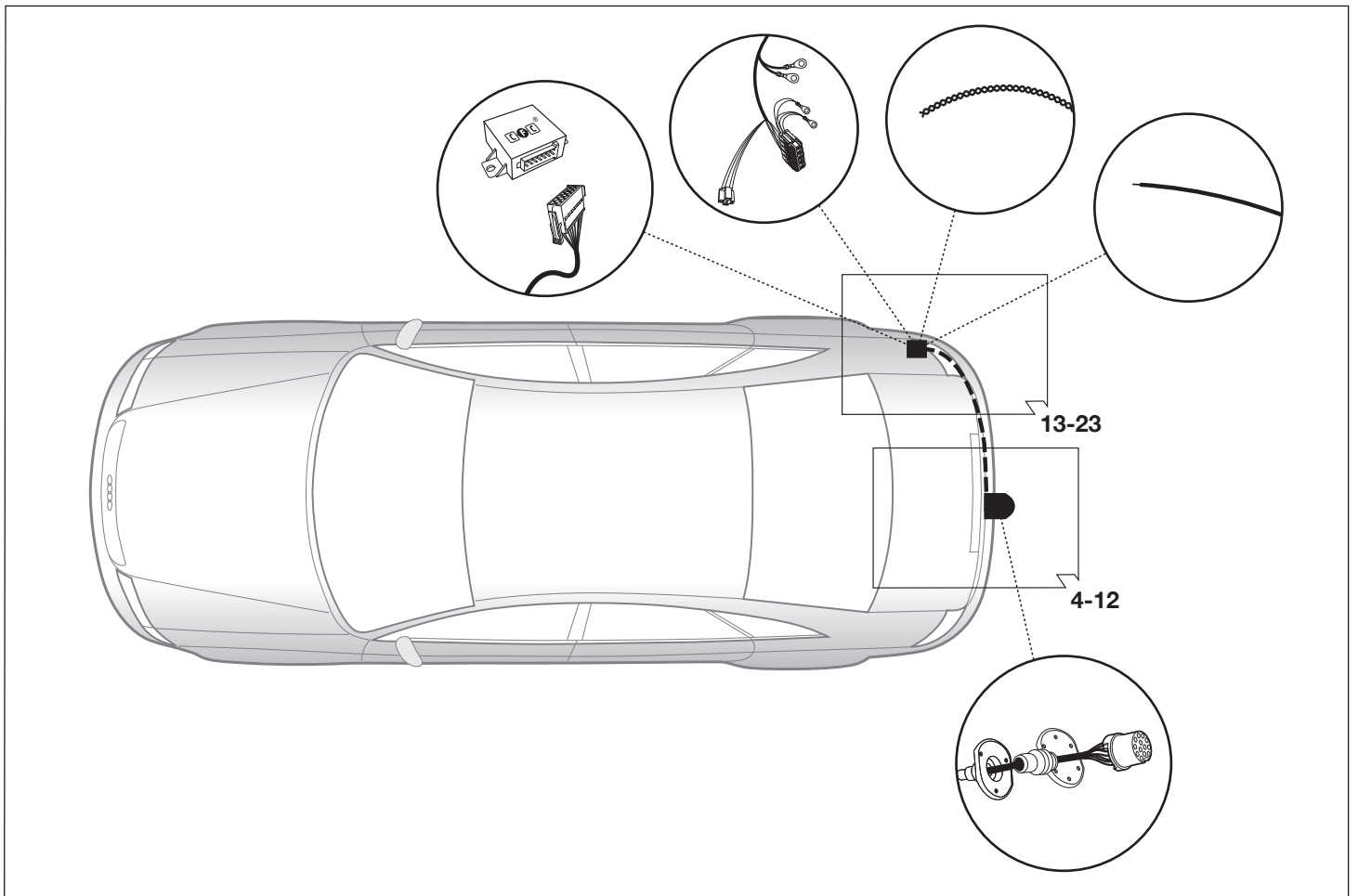
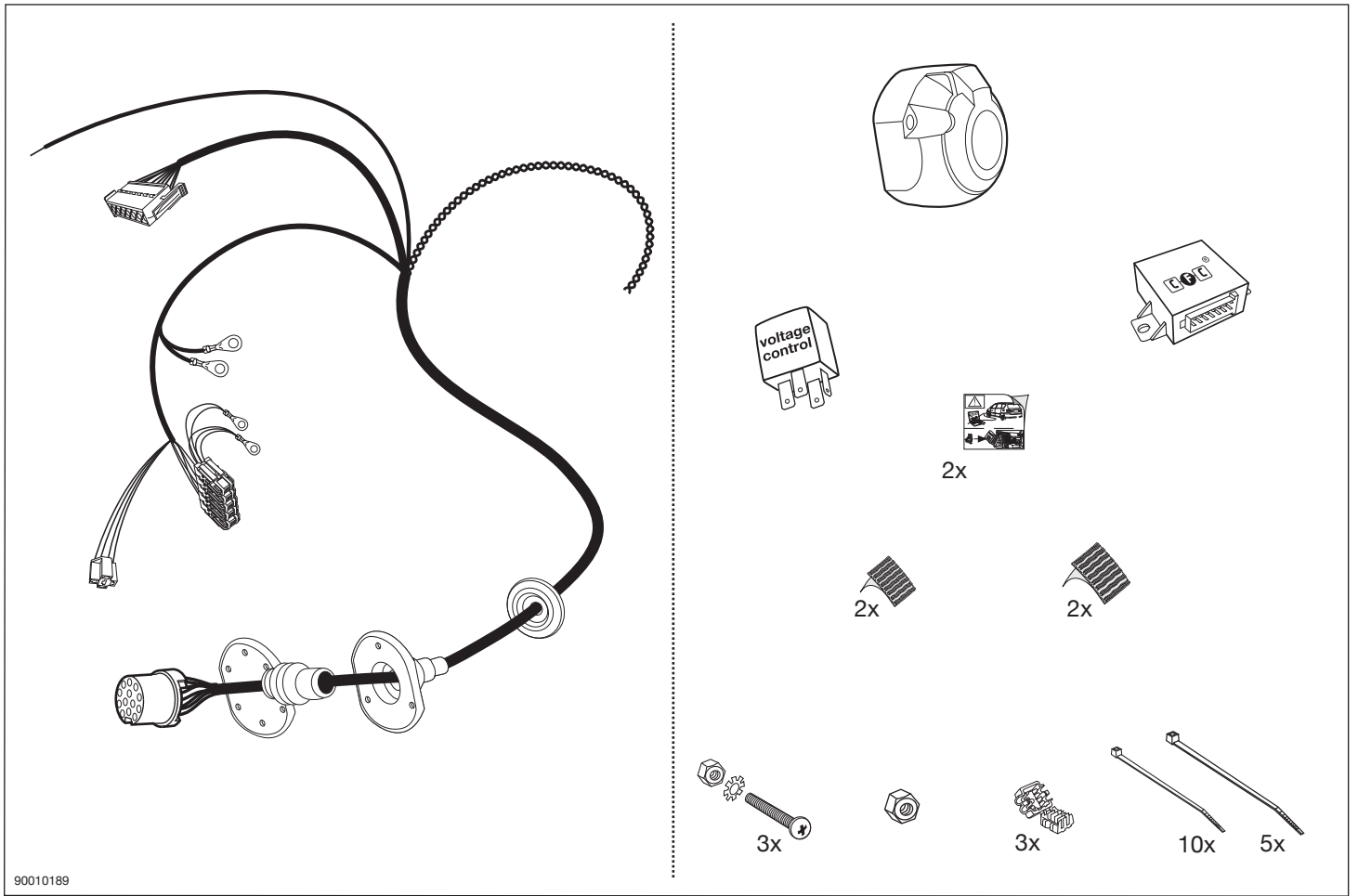

SYMBOL EXPLANATION

	left (58-L) respectively right (58-R) tail light
	stop light (54) / high mounted, third stop light (54)
	turn signal indicator left
	turn signal indicator right
	rear fog light(s)
	reversing light(s)
	Permanent power supply / 13pin socket, chamber 9
	charging wire for trailer fridge / 13pin socket, chamber 10
	trailer / trailer recognition
	Permanent current power supply
	Ground or Earth (31)
	ground connection battery terminal lug
	positive connection battery terminal lug
	fuse / fuse capacity 20 Ampère

	cigarette lighter / accessory socket
	loudspeaker / buzzer
	Park Distance Control
	switch / source of function
	Connect together
	Disconnect
	Look at / See further information
	Look carefully at selected area
	Present / Occupied / OK
	Not present / Not occupied / Not OK
	left
	right
	acoustic indication
	attention / important advice

90500760

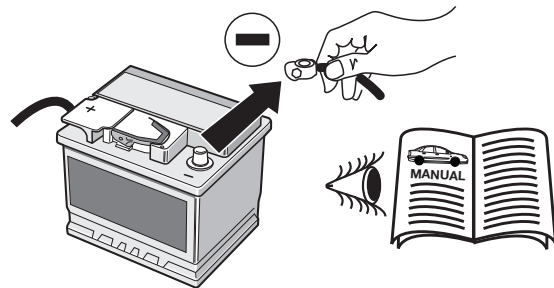

IMPORTANT!

In order to avoid mal-functions and damage to the vehicle's electrical system the earth terminal **must** be disconnected from the vehicle's battery **before starting work!**

Both the trailer module and the vehicle's control unit for the electrical system can be damaged during work on the CAN data bus connections if the battery is not disconnected!

Please pay attention to the manufacturer's instructions when disconnecting and reconnecting the vehicle's battery!

90010216

1

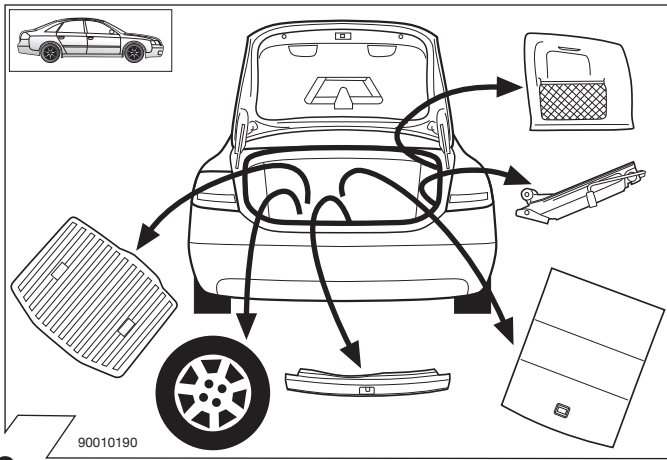

2

90010190

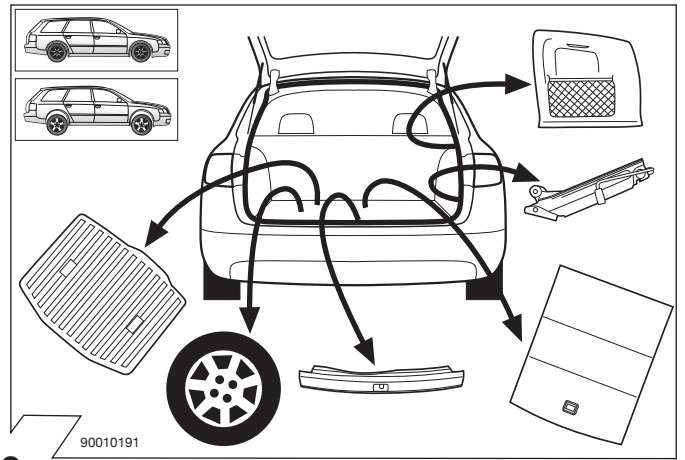

3

90010191

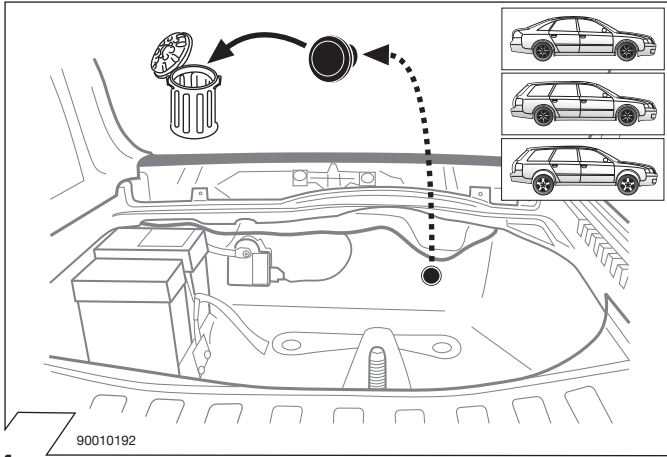

4

90010192

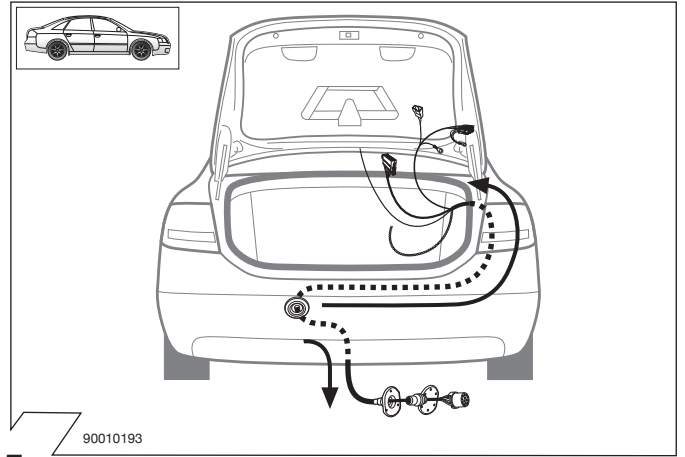

5

90010193

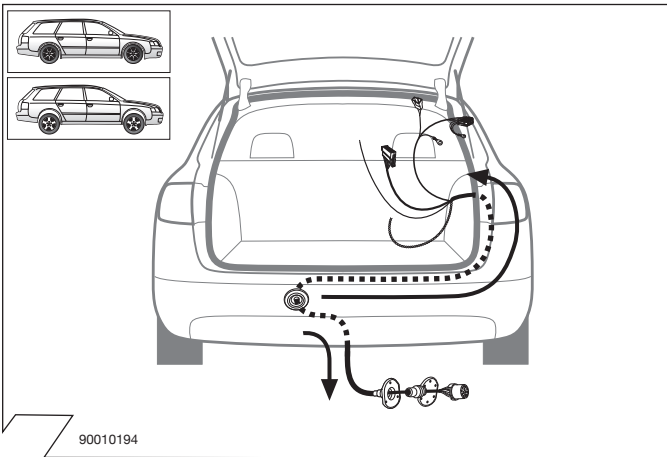

6

90010194

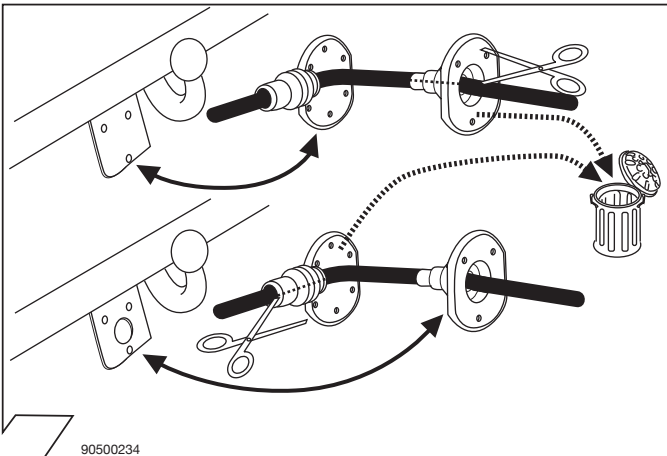

7

90500234

ISO 11446	Belegung der Steckdose / Maximale Ausgangsleistung Socket configuration / Maximum power output Correspondance des contacts de la prise / Puissance de sortie maximale Abbinamento della presa / Uscita di alimentazione massima Indeling van de stekkerdoos / maximaal uitgangsvermogen		
	1/L	YL	21W
	2	BL	42W
	3/31	WT	
	4/R	GN	21W
	5/58-R	BR	52W
	6/54	RD	63W
	7/58-L	BK	52W
	8	PK	42W
	9	OR	240W
	10	GY	180W
	11	WT/BK	
	12		
	13	WT/RD	

8

90020157

	GB	D	E	F	I	P	NL	DK	N	S	FIN	CZ	H	PL
BK	Black	Schwarz	Negro	Noir	Nero	Preto	Zwart	Sort	Svart	Svart	Musta	Černá	Fekete	Czarny
RD	Red	Rot	Rojo	Rouge	Rosso	Vermelho	Rood	Rød	Röd	Röd	Punainen	Červená	Piros	Czerwony
GN	Green	Grün	Verde	Vert	Verde	Verde	Groen	Grøn	Grønt	Grön	Vihreä	Zelená	Zöld	Zielony
OR	Orange	Orange	Naranja	Orange	Arancione	Laranja	Oranje	Orange	Orange	Orange	Oranssi	Oran•ová	Narancs	Pomarańczowy
VT	Violet	Violett	Violeta	Violet	Viola	Violeta	Violet	Violet	Fiolett	Violett	Violetti	Fialová	Ibolya	Fioletowy
PK	Pink	Pink	Pink	Rose	Rosa	Cor-de-Rosa	Paars	Pink	Pink	Rosa	Pinkki	Růžová	Rózsaszín	Różowy
BL	Blue	Blau	Azul	Bleu	Blu	Azul	Blauw	Blå	Blått	Blå	Sininen	Modrá	Kék	Niebieski
YL	Yellow	Gelb	Amarillo	Jaune	Giallo	Amarelo	Geel	Gul	Gult	Gul	Keltainen	•lutá	Sárga	Żółty
WT	White	Weiss	Blanco	Blanc	Bianco	Branco	Wit	Hvid	Hvitt	Vit	Valkoinen	Bílá	Fehér	Biały
BR	Brown	Braun	Marrón	Brun	Marrone	Marrom	Bruin	Brun	Brunt	Brun	Ruskea	Hnědá	Barna	Brazowy
GY	Grey	Grau	Gris	Gris	Grigio	Cinzeno	Grijs	Grå	Grått	Grå	Harmaa	•edá	Szürke	Szary

90500580

9

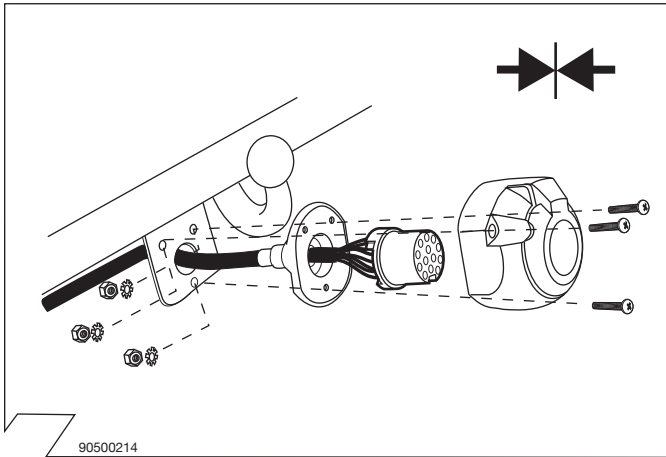

90500214

10

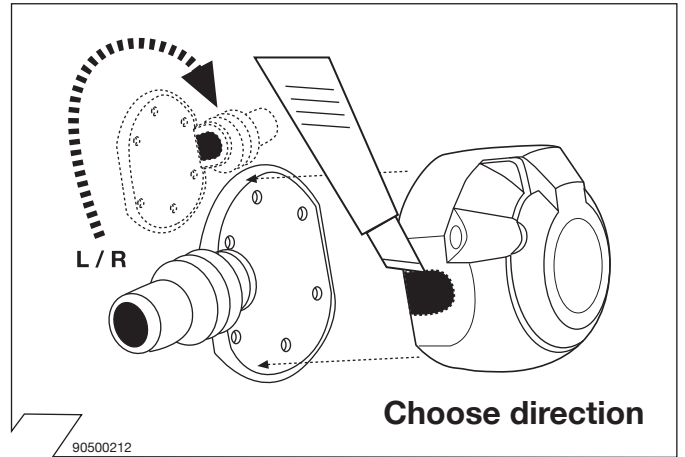

90500212

11

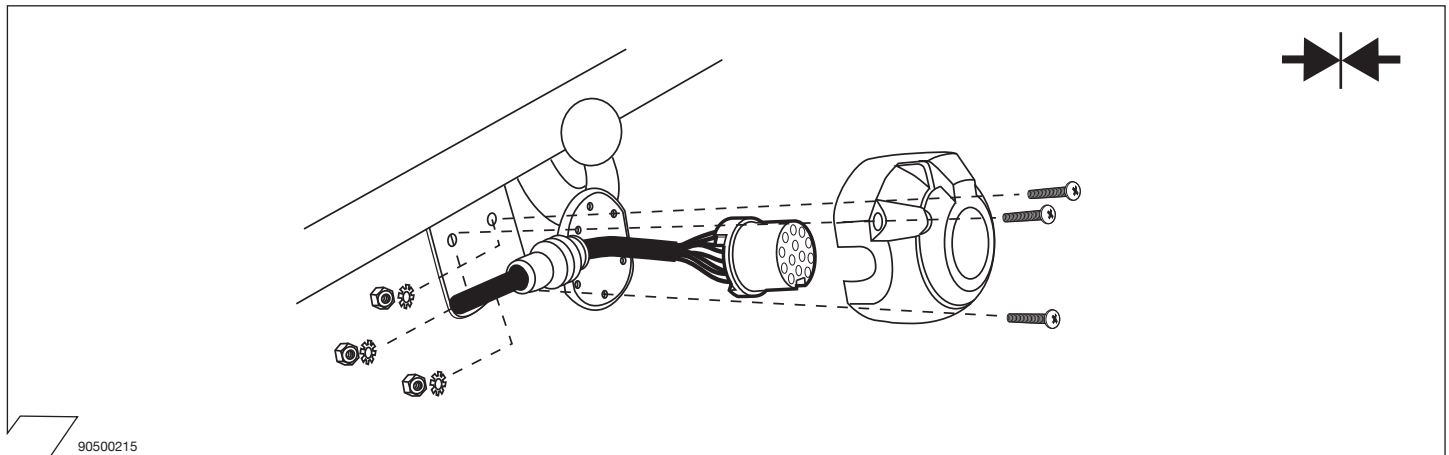

90500215

12

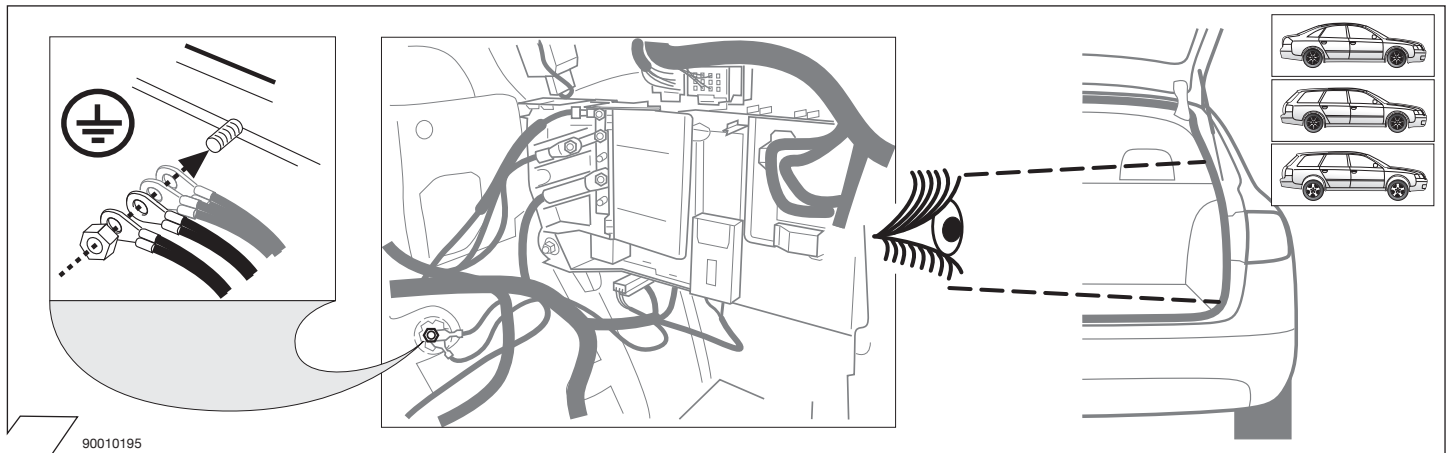

90010195

13

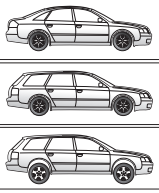

B+/30 battery feed stud **available** at the left beside fuse box.

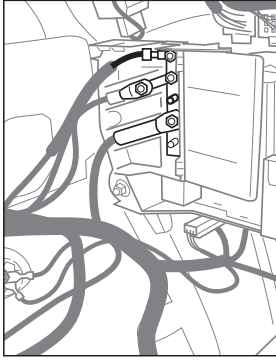

15
17 - 32

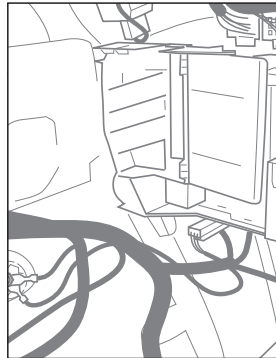
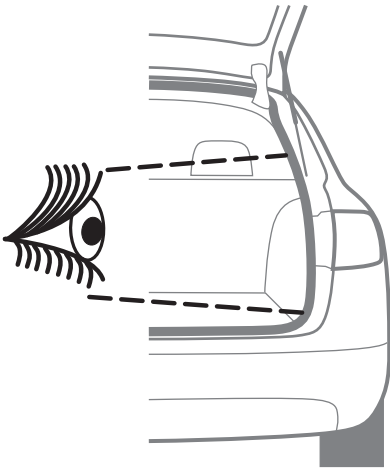

16 - 32

B+/30 battery feed stud **not available** at the left beside fuse box.

14

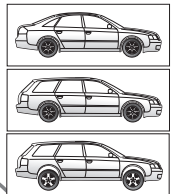
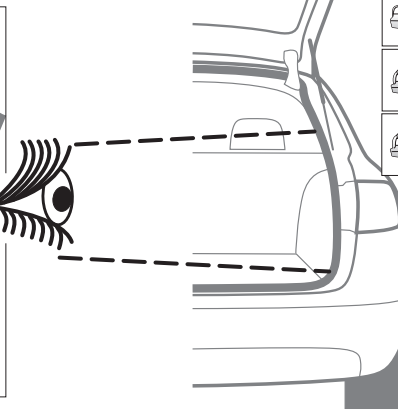
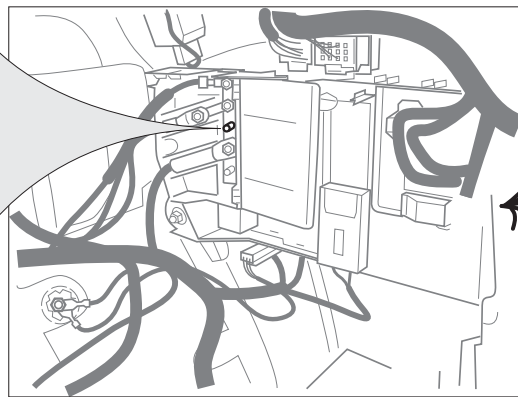
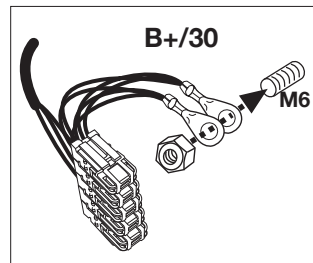

90010196

15

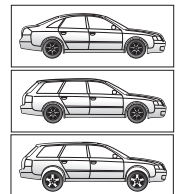
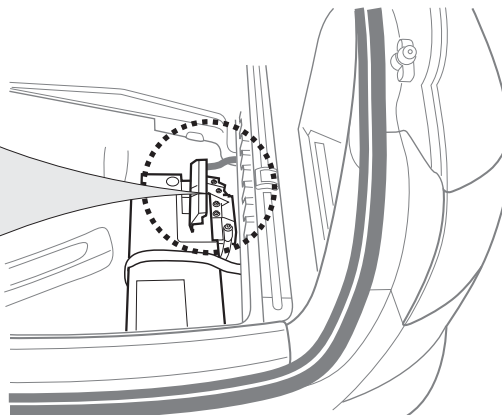
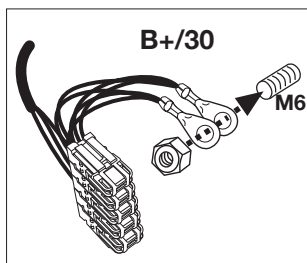

16

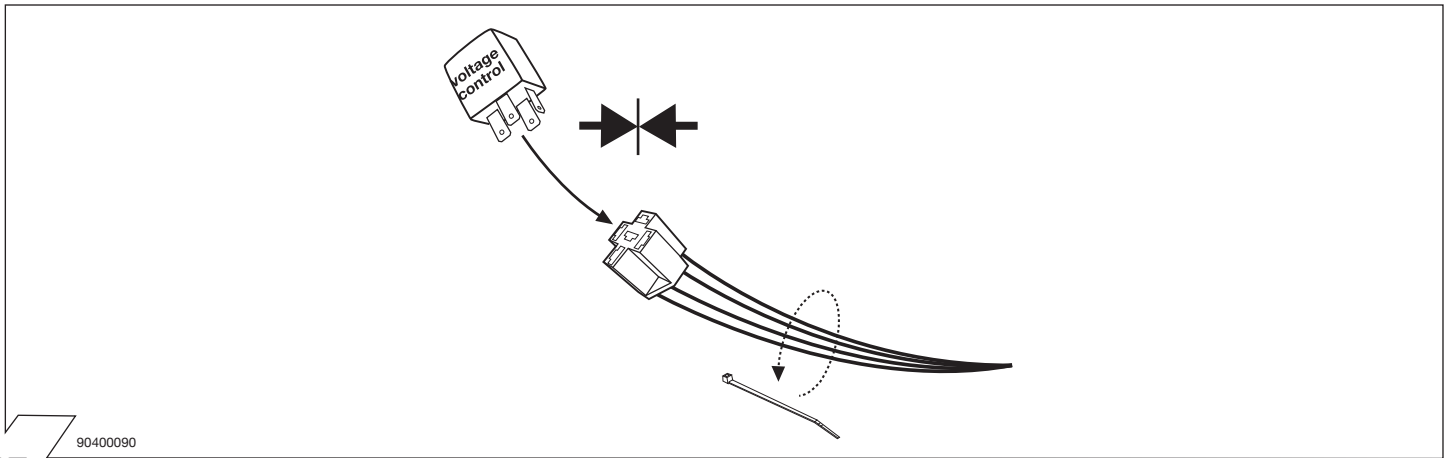

90400090

17

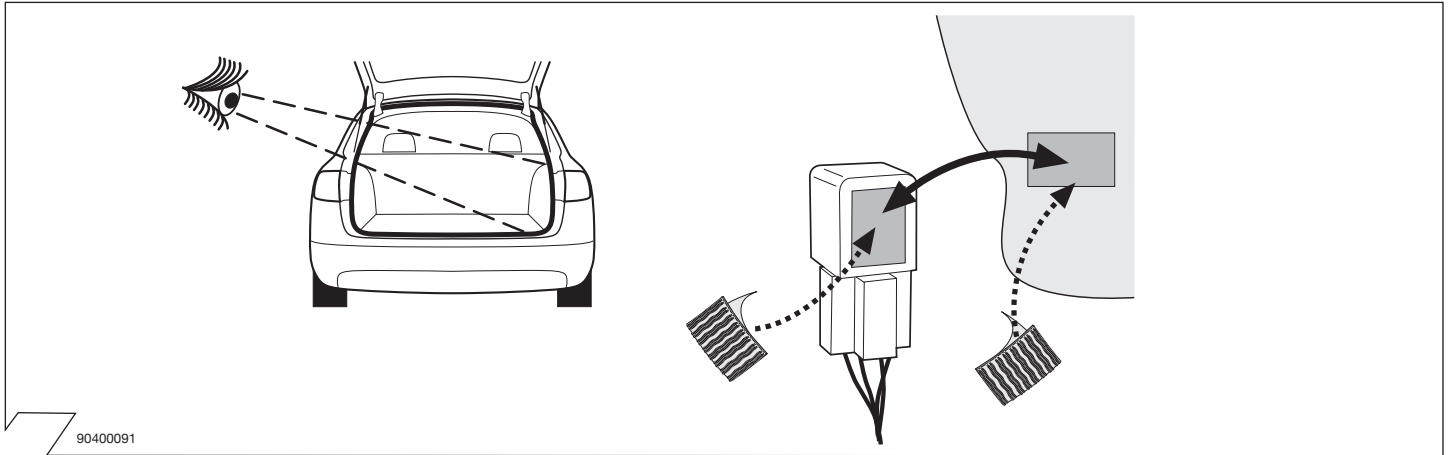

90400091

18

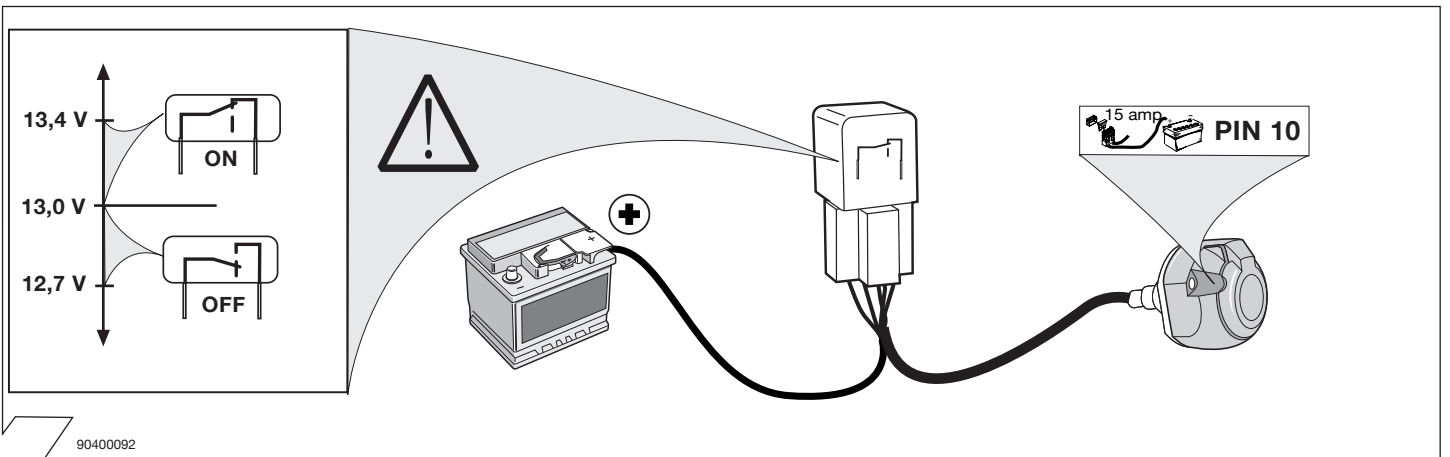

90400092

19

ATTENTION

The Voltage Control Module (VCM) in this kit is designed to be self switching at a pre-set voltage input. With the engine started, the switched output (e.g. caravan fridge or alternative), pin 10, will switch on at a preset figure of 13,4 volts.

When the engine is switched off, the switched output will remain live until the vehicle battery voltage drops to a preset figure of approx 12,7 volts.

NOTE: The cut-off voltage depends on the condition of the vehicle battery, power consumption of the fridge etc. In all cases, the cut-off figure is preset so the vehicle engine can be started at any time.

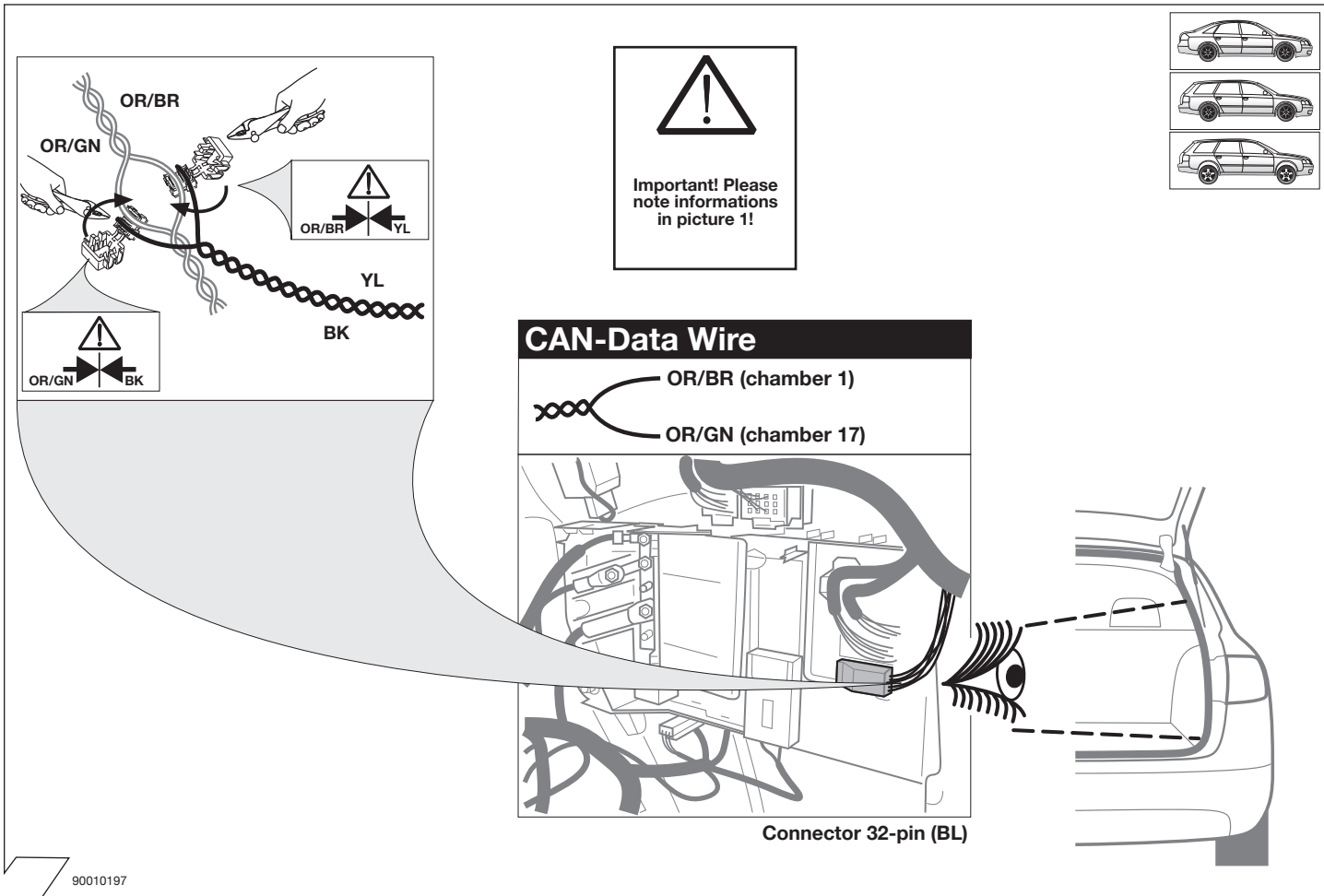

20

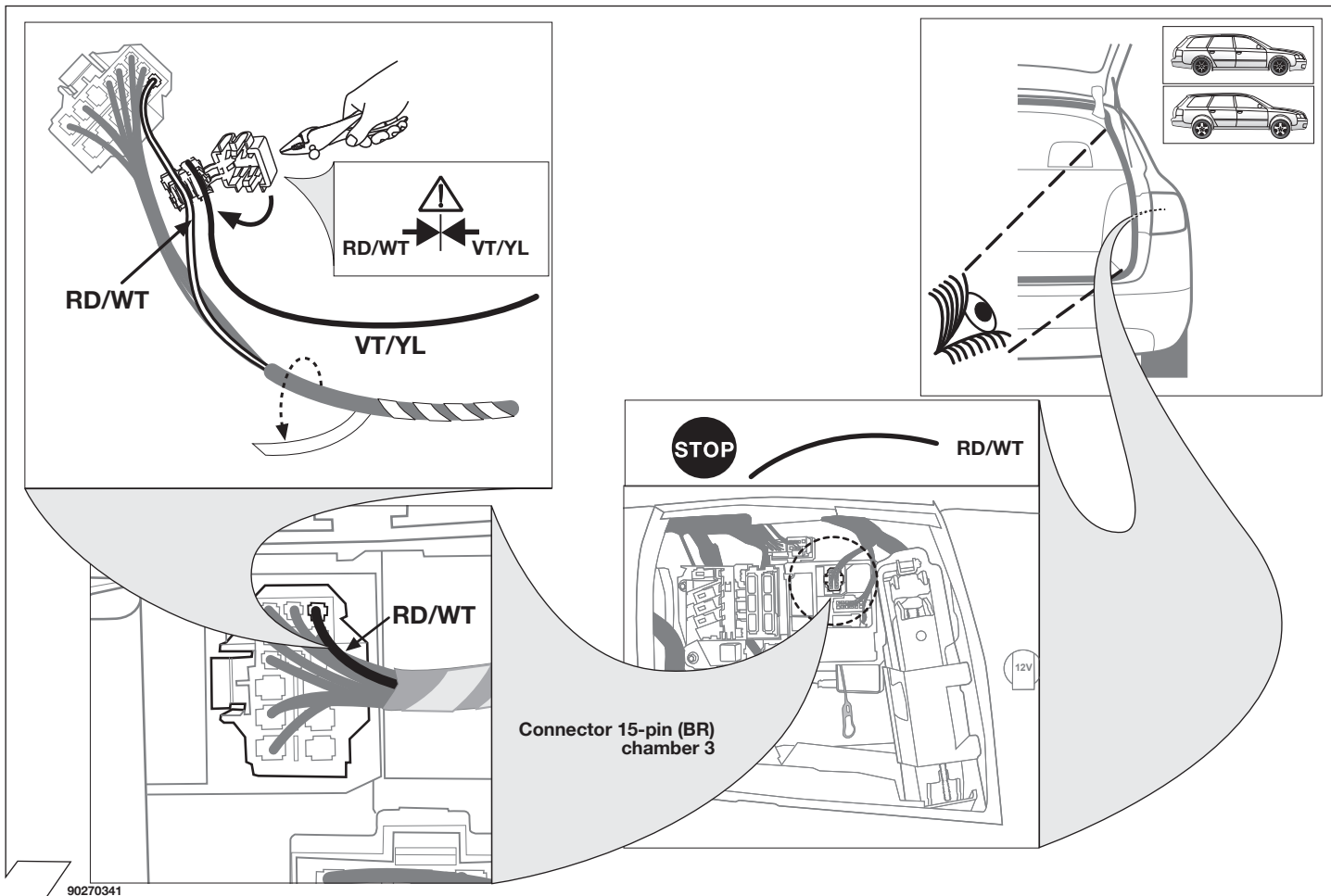

21

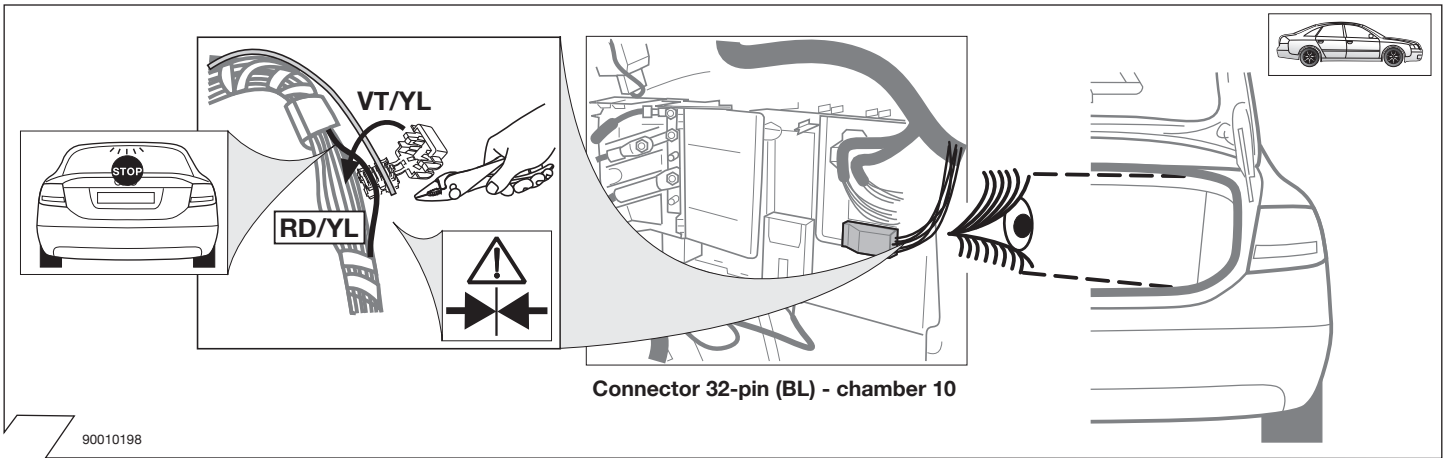

22

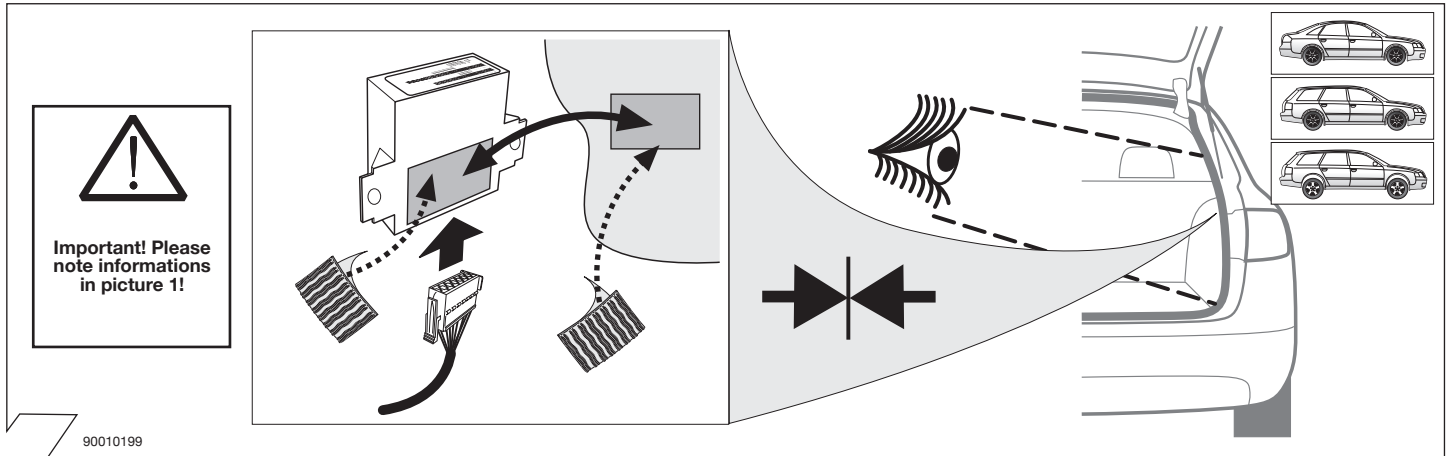

23

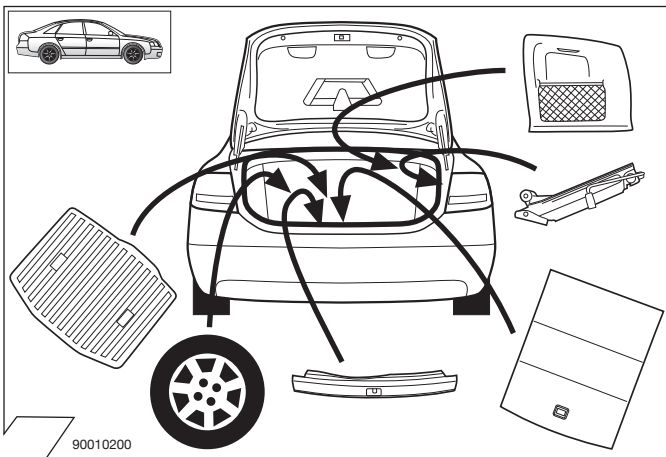

24

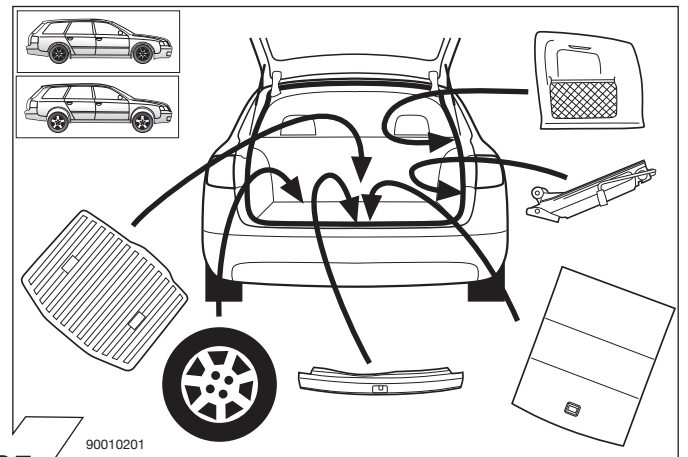

25

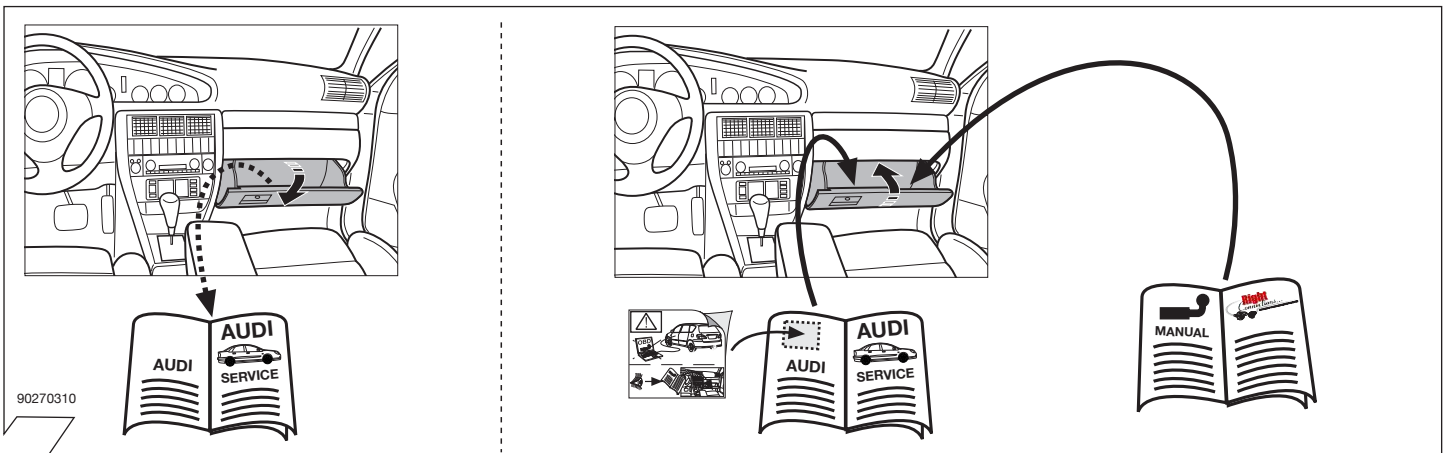

26

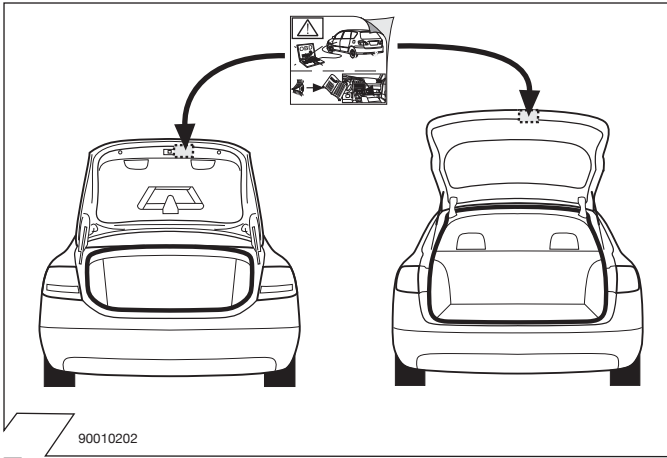

27

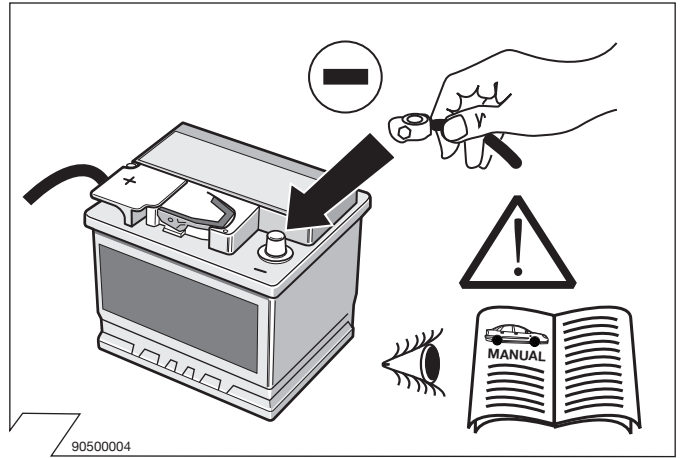

28

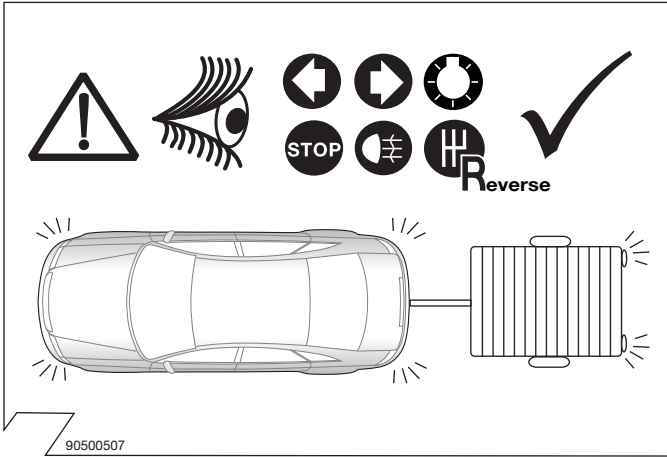

29

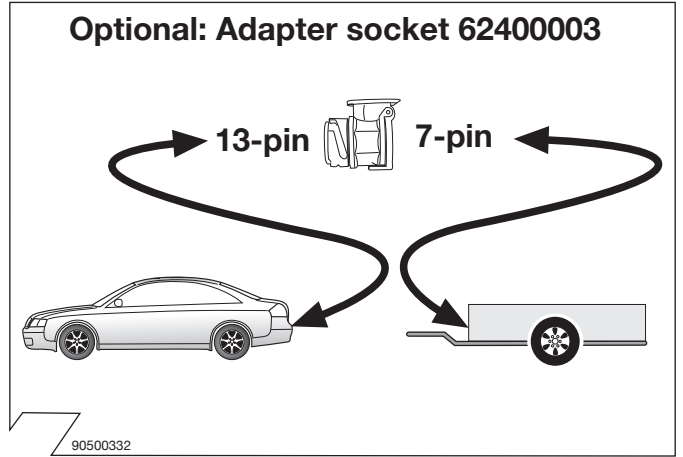

30

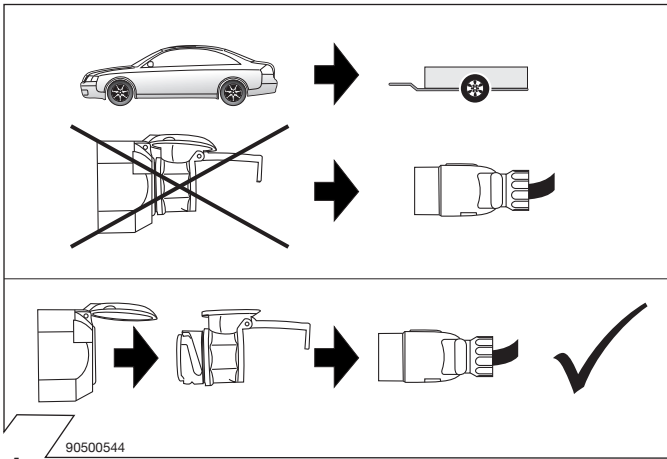

31



Code Control unit

page 11



GB

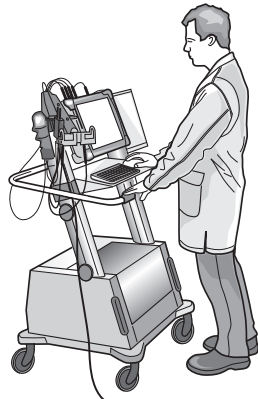

Set up trailer operation

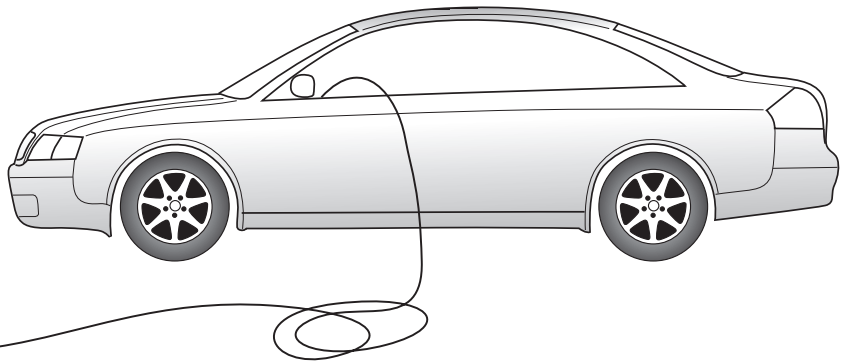

Match the vehicle code in the following control units via selected diagnostics by coding "towing hitch installed" (see coding example on page 11):

- 19 Diagnosis interface for data bus
- 45 Brake electronics ESP
- 13 Distance control ACC
- 34 Level control
- 01 Engine control unit
- 76 Park distance control

After installing and enabling the electric kit, the following entry may show up in the fault memory:

J345 control unit for trailer detection - no communication - intermittent

This entry does not affect the functions of the trailer socket and can be ignored.

Explanation:

Communication between the trailer detection control unit (CFC module) and the vehicle's power supply control unit is immediately interrupted when the signal "Ignition (terminal 15) off" is issued. That way the vehicle's energy management system is not unnecessarily strained.



GB

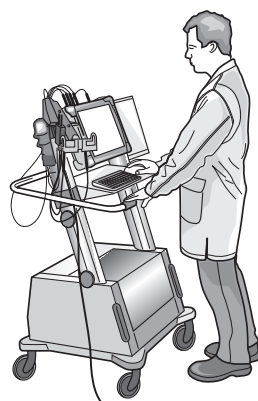

Set up trailer operation

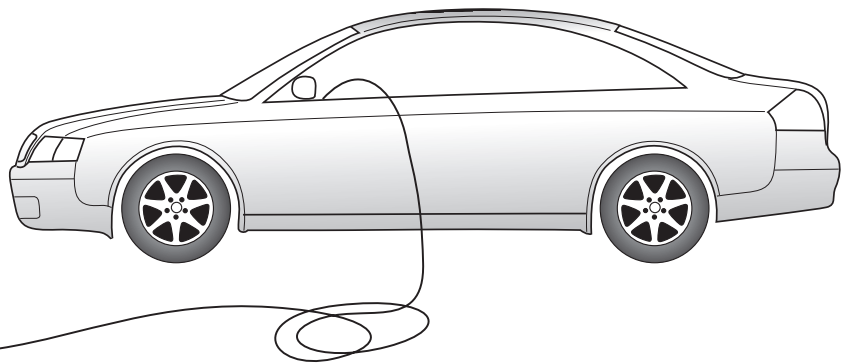

Coding AUDI A6 / ALLROAD QUATTRO

Please note:

The procedure described below for encoding and enabling the trailer mode only serves for a general orientation and can vary greatly depending on the model (motorisation / equipment). If necessary further control units will have to be adapted by means of guided trouble-shooting (e.g. motor electronics, distance control ACC).

Encoding the ESP control unit:

- Guided troubleshooting
- Skip
- Function / component selection
- Chassis
- Brake system
- Self-diagnosing systems
- 03 - ABS and ESP
- J104 control unit for ABS and ESP
- Encode control unit (encode trailer coupling as installed)

Encoding vehicles with ride-control system (e.g. Allroad Quattro):

- Vehicle self-diagnosis
- Gateway installation list
- 34 - Ride-control system
- 07 - Encode control unit
- Add the value 10 the current code & re-program

Encoding vehicles with PDC :

- Vehicle self-diagnosis
- Gateway installation list
- 76 - PDC
- 07 - Encode control unit
- Add the value 10000 the current code & re-program

Encoding the diagnosis interface for the data bus:

- Vehicle self-diagnosis
- Gateway installation list
- 19 - Diagnosis interface for the data bus
- Read / write long code
- 69 - Trailer function (switch to encoded!)